



hover

barcelona lights

Snapshot  
21/22



Big Bang	4
Candle	8
Circular	14
Cocktail	26
Folie	32
Helios	38
Ilargi	44
Invisible	50
Kira	56
Nut	60

# Big Bang

*Design by*  
Francesc Vilaró



The indirect light generated by this luminaire is reflected onto gold-coloured metal creating a halo of light that produces different effects.



*La luz indirecta que genera esta luminaria se refleja sobre una pieza de metal dorado que crea un halo lumínico produciendo diferentes efectos.*

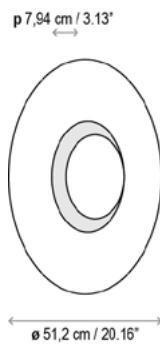



---

## Big Bang A / 01

DRY |  |  22.5 W LED / CRI: 90 / 3000°K  
760 lm light source / fuente de luz

---

Finishes  
*Acabados*



White  
*Blanco*

# Candle

*Design by*  
Benedito Design









The adaptation of a classic candle holder with a LED light source has produced this delicate luminaire. Its light creates and accentuates different areas. The way it projects the light creates and highlights the spaces, creating warm, natural environments.

*La adaptación de un portavelas clásico con una fuente de luz LED ha producido esta delicada luminaria. Su luz crea y acentúa diferentes áreas. La forma en que proyecta la luz crea y resalta los espacios, creando ambientes cálidos y naturales.*

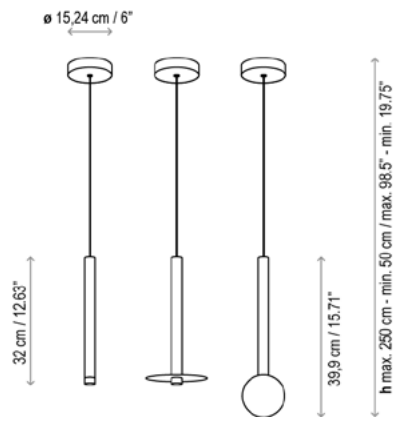



Candle S/1L

DRY |  |  6 W LED / CRI: 90 / 2700°K  
 154 lm light source / fuente de luz

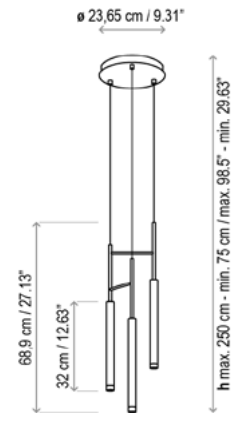

Candle S/3L

DRY |  |  11.2 W LED / CRI: 90 / 2700°K  
 462 lm light source / fuente de luz



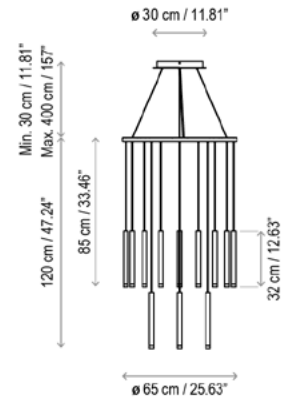
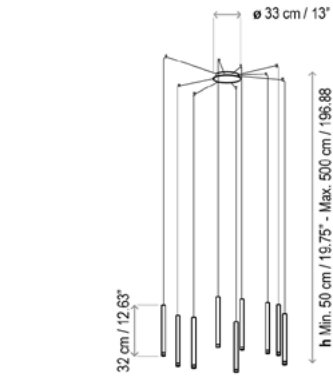
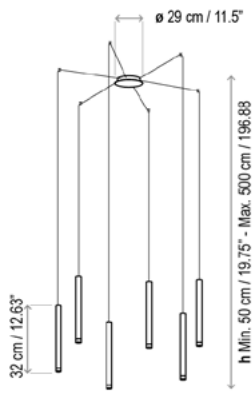

## Candle S/6L

DRY | 1-10V | 23 W LED / CRI: 90 / 2700°K  
922 lm light source / fuente de luz

## Candle S/9L

DRY | 0-10V | 32 W LED / CRI: 90 / 2700°K  
1586 lm light source / fuente de luz

## Candle S/15L

DRY | 0-10V | 54.7 W LED / CRI: 90 / 2700°K  
2310 lm light source / fuente de luz

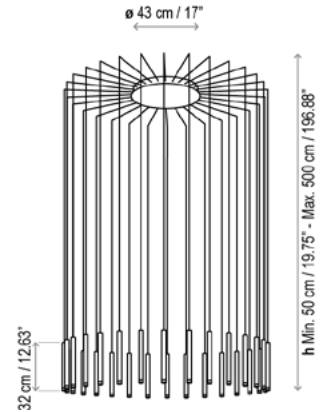
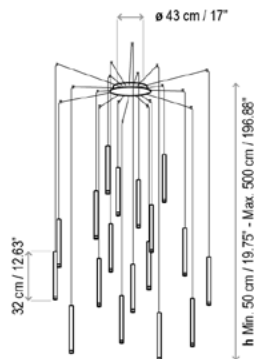
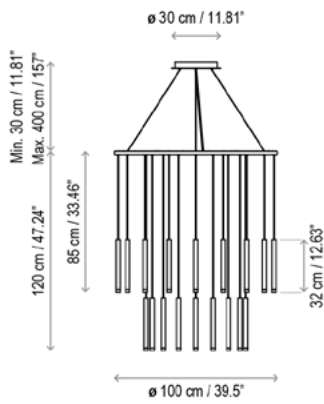

## Candle S/18L

DRY | 0-10V | 70.3 W LED / CRI: 90 / 2700°K  
3042 lm light source / fuente de luz

DRY | 0-10V | 60.2 W LED / CRI: 90 / 2700°K  
2772 lm light source / fuente de luz

## Candle S/30L

DRY | 0-10V | 107 W LED / CRI: 90 / 2700°K  
4620 lm light source / fuente de luz

## Finishes Acabados



Matte Gold  
Oro Mate

## Family Familia



# Circular

*Design by*  
Benedito Design



Circular is the result of the combination of design and architecture to create lights for large spaces. With this piece, Benedito Design accomplishes maximum expression with minimum materials. Circular offers great versatility with its combination of formats and finishes.

*Circular es el resultado de unir diseño y arquitectura en la creación de luminarias para grandes espacios. Benedito Design consigue con esta pieza la máxima expresión con la mínima materia. Circular ofrece una gran versatilidad combinando sus diferentes formatos y acabados.*









Inward light  
*Luz interior*

Outward light  
*Luz exterior*

Downward light  
*Luz inferior*

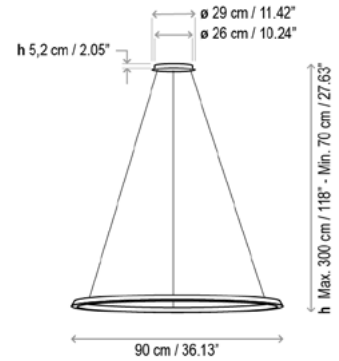

## Circular S/60/H

Inward light / *luz interior*

DRY | 0-10V | 39.8 W LED / CRI: 90 / 2700°K  
1264 lm light source / *fuentes de luz*

Outward light / *luz exterior*

DRY | 0-10V | 39.8 W LED / CRI: 90 / 2700°K  
1270 lm light source / *fuentes de luz*

Downward light / *luz inferior*

DRY | 0-10V | 39.8 W LED / CRI: 90 / 2700°K  
1209 lm light source / *fuentes de luz*

## Circular S/90/H

Inward light / *luz interior*

DRY | 0-10V | 52 W LED / CRI: 90 / 2700°K  
1438 lm light source / *fuentes de luz*

Outward light / *luz exterior*

DRY | 0-10V | 52 W LED / CRI: 90 / 2700°K  
1448 lm light source / *fuentes de luz*

Downward light / *luz inferior*

DRY | 0-10V | 52 W LED / CRI: 90 / 2700°K  
1311 lm light source / *fuentes de luz*

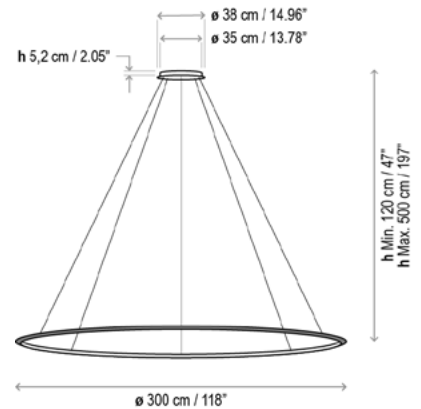

## Circular S/120/H

Inward light / *luz interior*

DRY | 0-10V | 70 W LED / CRI: 90 / 2700°K  
2106 lm light source / *fuentes de luz*

Outward light / *luz exterior*

DRY | 0-10V | 70 W LED / CRI: 90 / 2700°K  
2960 lm light source / *fuentes de luz*

Downward light / *luz inferior*

DRY | 0-10V | 70 W LED / CRI: 90 / 2700°K  
2421 lm light source / *fuentes de luz*

## Circular S/200/H

Inward light / *luz interior*

DRY | 0-10V | 150 W LED / CRI: 90 / 2700°K  
3670 lm light source / *fuentes de luz*

Outward light / *luz exterior*

DRY | 0-10V | 150 W LED / CRI: 90 / 2700°K  
5092 lm light source / *fuentes de luz*

Downward light / *luz inferior*

DRY | 0-10V | 150 W LED / CRI: 90 / 2700°K  
4238 lm light source / *fuentes de luz*

## Circular S/300/H

Inward light / *luz interior*

DRY | 0-10V | 180 W LED / CRI: 90 / 2700°K  
5335 lm light source / *fuentes de luz*

Outward light / *luz exterior*

DRY | 0-10V | 180 W LED / CRI: 90 / 2700°K  
7626 lm light source / *fuentes de luz*

Downward light / *luz inferior*

DRY | 0-10V | 180 W LED / CRI: 90 / 2700°K  
6254 lm light source / *fuentes de luz*



Finishes  
*Acabados*



Black  
*Negro*



White  
*Blanco*



Gold  
*Dorado*

Family  
*Familia*

Circular Horizontal

S/60/H



S/90/H



S/120/H



S/200/H



S/300/H





Inward light  
Luz interior



Outward light  
Luz exterior

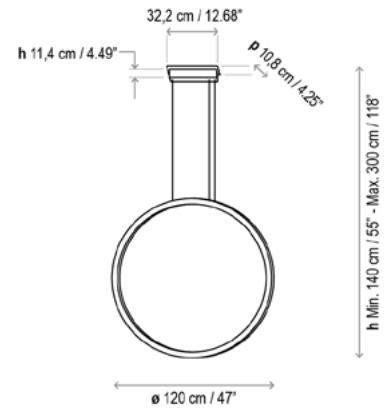
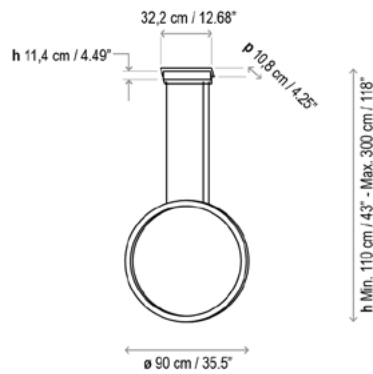
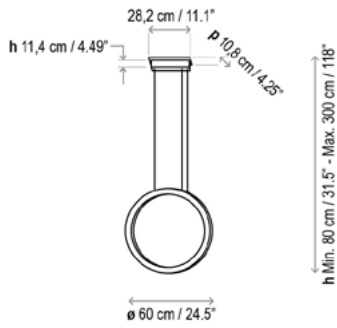

## Circular S/60/V

Inward light / luz interior



DRY   59.8 W LED / CRI: 90 / 2700°K  
1264 lm light source / fuente de luz

Outward light / luz exterior



DRY   59.8 W LED / CRI: 90 / 2700°K  
1209 lm light source / fuente de luz

## Circular S/90/V

Inward light / luz interior



DRY   52 W LED / CRI: 90 / 2700°K  
1438 lm light source / fuente de luz

Outward light / luz exterior

DRY   52 W LED / CRI: 90 / 2700°K  
1311 lm light source / fuente de luz

## Circular S/120/V

Inward light / luz interior

DRY   66.9 W LED / CRI: 90 / 2700°K  
2106 lm light source / fuente de luz

Outward light / luz exterior

DRY   66.9 W LED / CRI: 90 / 2700°K  
2421 lm light source / fuente de luz



Finishes  
*Acabados*



Black  
*Negro*



White  
*Blanco*



Gold  
*Dorado*

Family  
*Familia*  
Circular Vertical

S/60/V



S/90/V



S/120/V





Inward light  
Luz interior



Outward light  
Luz exterior



Downward light  
Luz inferior

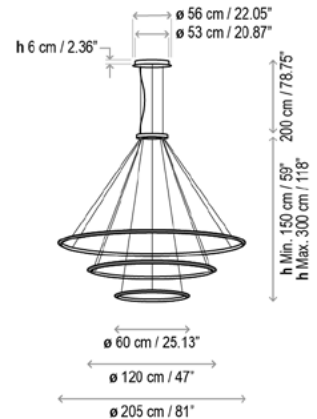
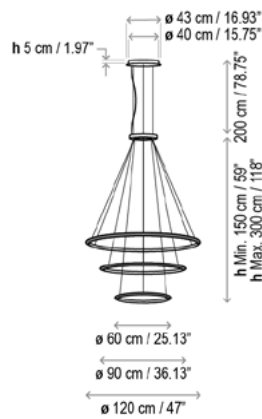
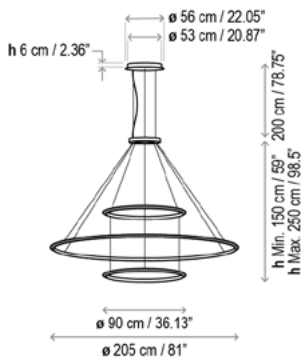

## Circular S/3L/90/200/90

Inward light / luz interior

DRY | 0-10V | 330 W LED / CRI: 90 / 2700°K  
6547 lm light source / fuente de luz

Outward light / luz exterior

DRY | 0-10V | 330 W LED / CRI: 90 / 2700°K  
7989 lm light source / fuente de luz

## Circular S/3L/120/90/60

Inward light / luz interior

DRY | 0-10V | 220 W LED / CRI: 90 / 2700°K  
4809 lm light source / fuente de luz

Outward light / luz exterior

DRY | 0-10V | 220 W LED / CRI: 90 / 2700°K  
6186 lm light source / fuente de luz

Downward light / luz inferior

DRY | 0-10V | 220 W LED / CRI: 90 / 2700°K  
4942 lm light source / fuente de luz

## Circular S/3L/200/120/60

Inward light / luz interior

DRY | 0-10V | 280 W LED / CRI: 90 / 2700°K  
7040 lm light source / fuente de luz

Outward light / luz exterior

DRY | 0-10V | 280 W LED / CRI: 90 / 2700°K  
9830 lm light source / fuente de luz

Downward light / luz inferior

DRY | 0-10V | 280 W LED / CRI: 90 / 2700°K  
7869 lm light source / fuente de luz



## Circular S/3L/300/200/120

Inward light / luz interior

DRY | 0-10V | 420 W LED / CRI: 90 / 2700°K  
11112 lm light source / fuente de luz

Outward light / luz exterior

DRY | 0-10V | 420 W LED / CRI: 90 / 2700°K  
15678 lm light source / fuente de luz

Downward light / luz inferior

DRY | 0-10V | 420 W LED / CRI: 90 / 2700°K  
12913 lm light source / fuente de luz

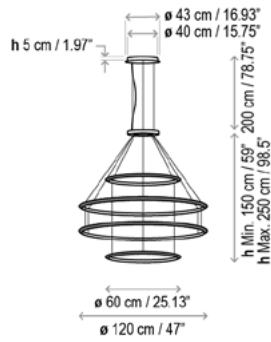

## Circular S/4L/60/120/120/60

Inward light / luz interior

DRY | 0-10V | 270 W LED / CRI: 90 / 2700°K  
6741 lm light source / fuente de luz

Outward light / luz exterior

DRY | 0-10V | 270 W LED / CRI: 90 / 2700°K  
6741 lm light source / fuente de luz

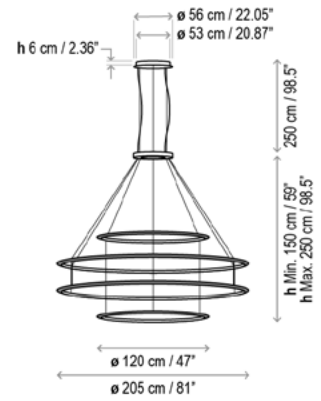

## Circular S/4L/120/200/200/120

Inward light / luz interior

DRY | 0-10V | 450 W LED / CRI: 90 / 2700°K  
11552 lm light source / fuente de luz

Outward light / luz exterior

DRY | 0-10V | 450 W LED / CRI: 90 / 2700°K  
16104 lm light source / fuente de luz

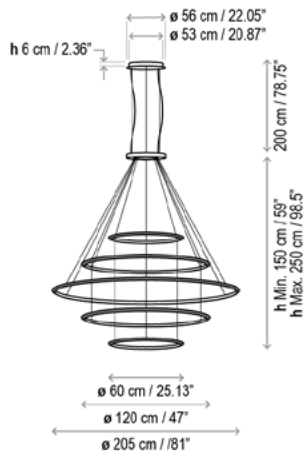

## Circular S/5L/60/120/200/120/60

Inward light / luz interior

DRY | 0-10V | 420 W LED / CRI: 90 / 2700°K  
10411 lm light source / fuente de luz

Outward light / luz exterior

DRY | 0-10V | 420 W LED / CRI: 90 / 2700°K  
14568 lm light source / fuente de luz

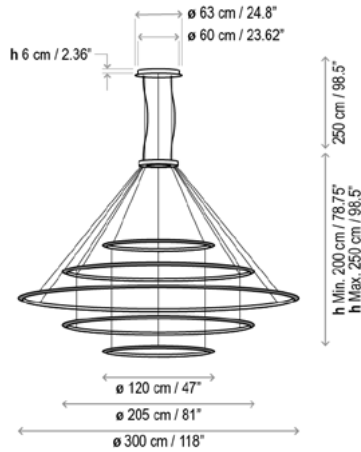

## Circular S/5L/120/200/300/200/120

Inward light / luz interior

DRY | 0-10V | 630 W LED / CRI: 90 / 2700°K  
16888 lm light source / fuente de luz

Outward light / luz exterior

DRY | 0-10V | 630 W LED / CRI: 90 / 2700°K  
23730 lm light source / fuente de luz



Finishes  
*Acabados*



Black  
*Negro*



White  
*Blanco*



Gold  
*Dorado*

Family  
*Familia*  
Circular



2x90  
1x200



1x60  
1x90  
1x120



1x60  
1x120  
1x200



1x120  
1x200  
1x300



2x60  
2x120



2x120  
2x200



2x60  
2x120  
1x200



2x120  
2x200  
1x300





# Cocktail

*Design by*  
Francesc Vilaró



Cocktail by Francesc Vilaró is balance. Creativity and industrialisation. Innovation and aesthetics. A portable lamp that works for you, creating and suggesting perfect atmospheres in restaurants, hotels, terraces and homes.

Its versatile design, with timeless shapes means you can invent atmospheres by creating compositions with different light points.

*Cocktail de Francesc Vilaró es equilibrio. Creatividad e industrialización. Innovación y estética. Una lámpara portátil que te acompaña, crea y sugiere atmósferas perfectas en restaurantes, hoteles, terrazas y hogares.*

*Su diseño versátil, de geometrías atemporales, permite inventar ambientes creando composiciones con diferentes puntos de luz.*







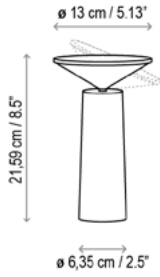

---

## Cocktail M/21/R

DRY |  3.6 W LED / CRI: 90 / 2700°K  
237 lm light source / fuente de luz



---

### Finishes *Acabados*



Matte Black  
*Negro Mate*



Matte White  
*Blanco Mate*



Olive Grey  
*Gris Oliva*

# Folie

*Design by*  
Christophe Mathieu







NEW COLLECTION  
WINTER

The Folie are part of a group of lights that can be fitted together or separately. Each lamp is made up of one or more lampshades depending on the model. They emit a filtered light through their ribbon shade.

*Las Folie forman parte de un grupo de luminarias que pueden colocarse en conjunto o por separado. Cada lámpara se compone de una o varias pantallas según cual sea el modelo. Emiten una luz tamizada a través de su pantalla de cinta.*





## Folie S/60

DRY |  3 x MAX 16 W E26 LED A19



## Folie S/70

DRY |  5 x MAX 16 W E26 LED A19



## Folie S/70.2

DRY |  5 x MAX 16 W E26 LED A19



Finishes  
*Acabados*



White  
*Blanco*



Cream  
*Crema*

Family  
*Familia*

S/60



S/70



S/70.2



# Helios

*Design by*  
Gonzalo Milà







The Helios wall lamp is an artisan product that gives off indirect light through the irregular cotton threads of its lampshade, drawing small shadows on the wall. Helios comfortably adapts to the language and personality of organic environments and wabi-sabi aesthetics.

Designed to be part of settings or light murals in applications where highly decorative results are sought.

*El aplique Helios es un producto artesanal que, a través de los hilos de algodón irregulares de su pantalla, deja pasar luz indirecta dibujando pequeñas sombras en la pared. Se adapta con comodidad al lenguaje y carácter de los ambientes orgánicos y de estética Wabi Sabi.*

*Pensada para formar parte de composiciones o murales de luz en aplicaciones donde se buscan resultados altamente decorativos.*



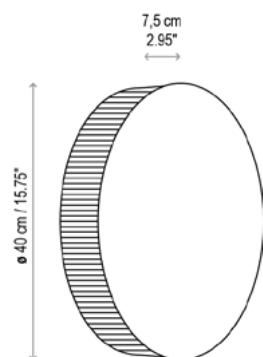
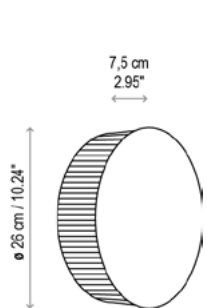

---

## Helios A/01

DRY | TRIAC | 16,8 W LED / CRI: 90 / 2700°K  
2000 lm light source / fuente de luz

---

## Helios A/02

DRY | TRIAC | 18 W LED / CRI: 90 / 2700°K  
2700 lm light source / fuente de luz

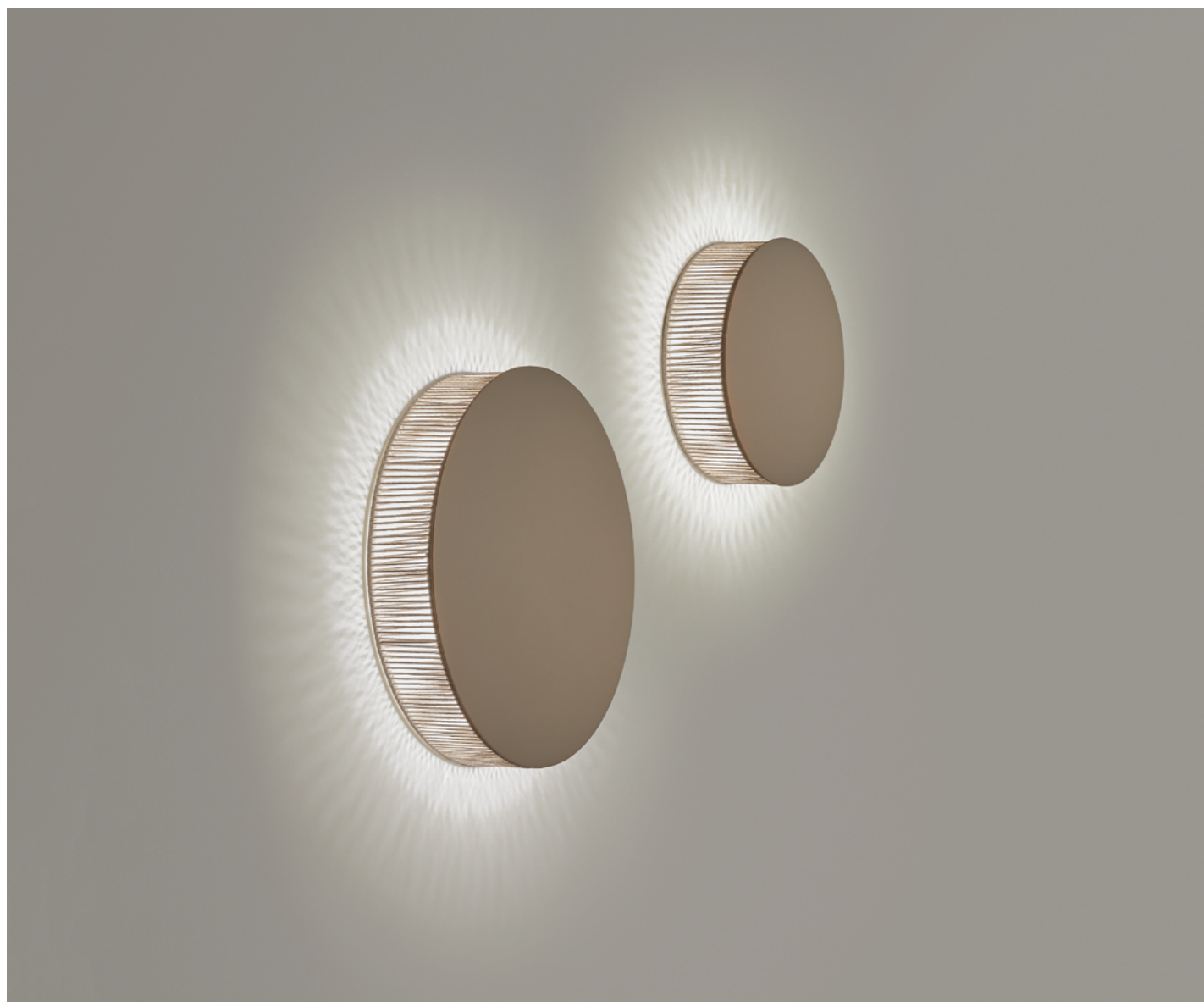



Finishes  
*Acabados*

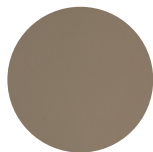

Oak Brown  
*Marrón Roble*

Family  
*Familia*

A/01



A/02



# Ilargi

*Design by*  
Iratzoki-Lizaso







Ilargi, designed by Basque studio Iratzoki Lizaso, takes shape in a subtle and minimalist piece where a wooden wand sits between traditionally hand-blown glass spheres.

*Ilargi, diseñada por el estudio vasco Iratzoki Lizaso, se materializa en una intervención sutil y mínima en la que una vara de madera se introduce en unas esferas de vidrio soplado hechas a mano de manera tradicional.*

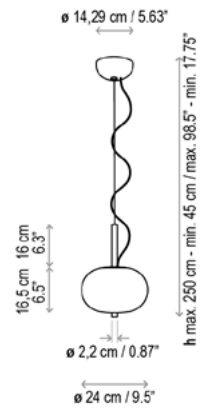



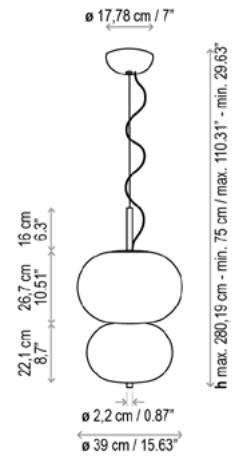
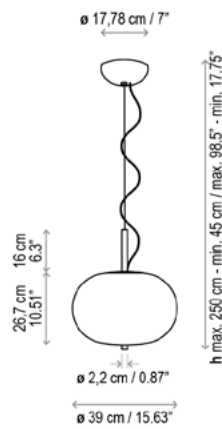
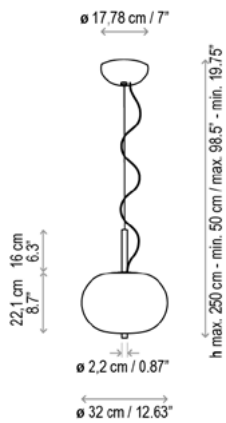

## Ilargi S/24

DRY |  |  10.3 W LED / CRI: 90 / 2700°K  
641 lm light source / fuente de luz



## Ilargi S/32

DRY |  |  14.8 W LED / CRI: 90 / 2700°K  
1054 lm light source / fuente de luz

## Ilargi S/39/01

DRY |  |  25.5 W LED / CRI: 90 / 2700°K  
1507 lm light source / fuente de luz

## Ilargi S/39/02

DRY |  |  39.6 W LED / CRI: 90 / 2700°K  
2560 lm light source / fuente de luz





Finishes  
*Acabados*



Dark Wood  
*Madera Oscura*



Light Wood  
*Madera Clara*

Family  
*Familia*

S/24



S/32



S/39/01



S/39/02



# Invisible

*Design by*  
Francesc Vilaró



The simplicity of this collection makes it unique and gives it authenticity and an individual identity. The different positions for its arms and heads generate multiple compositions that convey a sense of almost complete weightlessness.

*La simplicidad de esta colección la hace única, auténtica y con identidad propia. Las diferentes posiciones de sus brazos y cabezales generan múltiples composiciones que transmiten una percepción casi de ingravidez.*





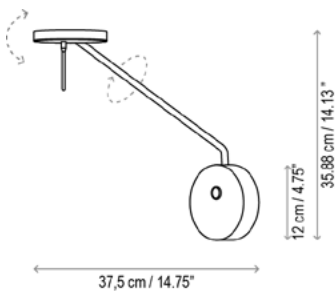

## Invisible A/01

DRY | | 13 W LED / CRI: 90 / 2700°K  
551 lm light source / fuente de luz

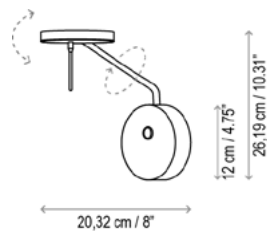

## Invisible A/02

DRY | | 13 W LED / CRI: 90 / 2700°K  
551 lm light source / fuente de luz

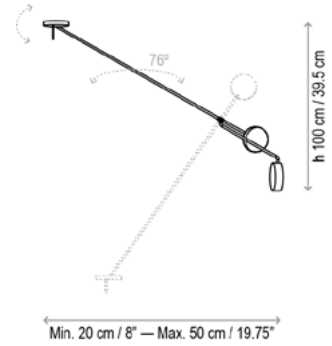

## Invisible A/03

DRY | | 13 W LED / CRI: 90 / 2700°K  
551 lm light source / fuente de luz

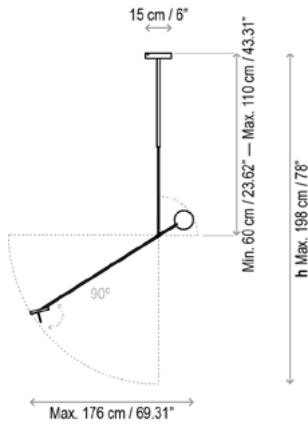

## Invisible PF/1L

DRY | | 10.6 W LED / CRI: 90 / 2700°K  
511 lm light source / fuente de luz

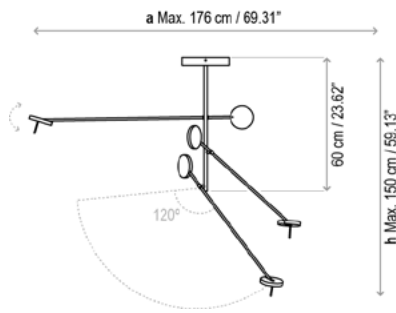

## Invisible PF/3L

DRY | | 30 W LED / CRI: 90 / 2700°K  
1533 lm light source / fuente de luz

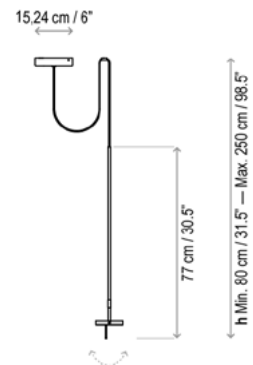

## Invisible S/1L

DRY | | 11.5 W LED / CRI: 90 / 2700°K  
511 lm light source / fuente de luz



Finishes  
*Acabados*



Matte Black  
*Negro Mate*

Family  
*Familia*

A/01



A/02



A/03



PF/1L



PF/3L



S/1L



# Kira

*Design by*  
Danos Salgados





*Image does not show North American backplate*

The Kira wall lamp is a light box that emits an aura of warm luminosity around its inner perimeter. In addition, it emits lower light through an LED plate and there is the option to add a button with 3 dimming settings.

With a fresh and lightweight design, Kira is mainly intended to be used in bedrooms.

*Los apliques Kira son una caja de luz que emite un aura de luminosidad cálida en el contorno de su perímetro interior. Además, emite luz inferior a través de una placa LED y puede disponer de un pulsador con 3 posiciones de regulación.*

*Con un aspecto fresh y ligero, Kira está pensada esencialmente como un producto a utilizar en habitaciones.*





Image does not show North American backplate

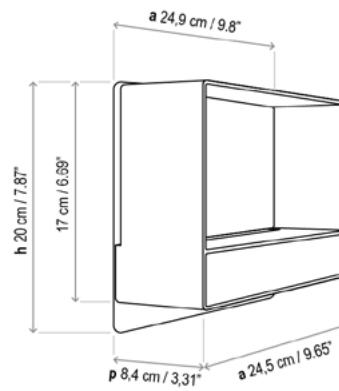

## Kira A/01

DRY | TRIAC | 0-10V |  8,4 W LED / CRI: 90 / 2700°K  
1100 lm light source / fuente de luz

Finishes  
*Acabados*



Matte White  
*Blanco Mate*

# Nut

*Design by*  
Estudi Manel Molina



Image does not show North American backplate



Nut is a collection of discreet lights that are characterised by their ergonomic and striking body. They are highly versatile products that can work as a headboard, a signalling lamp in corridors or a bathroom wall lamp.

They are easy and intuitive to use. The light beam can be directed from right to left at a 180° angle.

*Las Nut son una colección de luminarias discretas que se caracterizan por su cuerpo ergonómico y contundente. Son un producto altamente versátil que puede funcionar como cabecero de cama, lámpara de señalización en pasillos o aplique de baño.*

*Su manejo es fácil e intuitivo. Permiten una orientación del haz de luz en sentido de derecha a izquierda en un ángulo de 180°.*

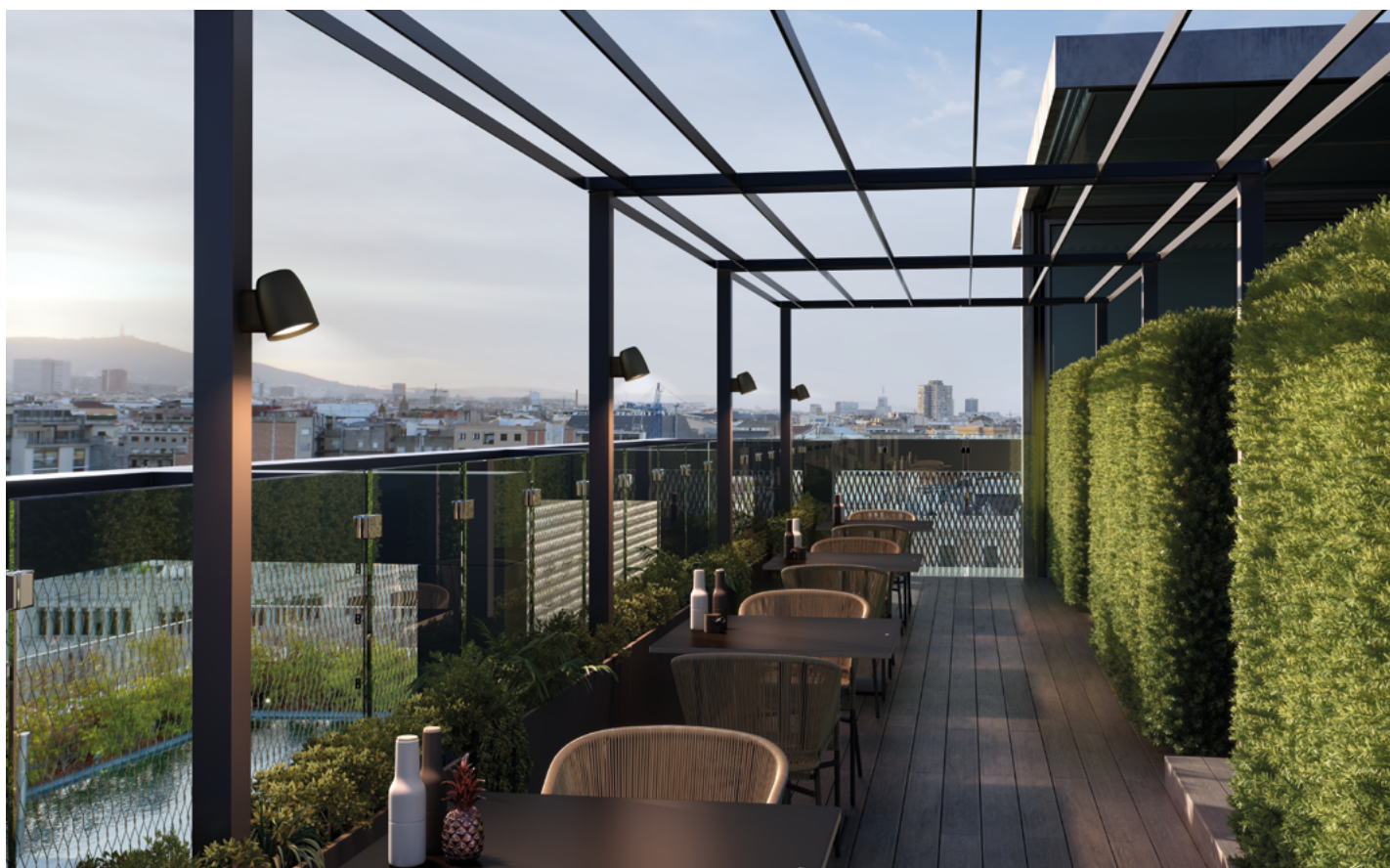
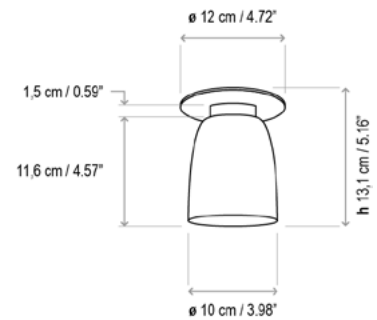
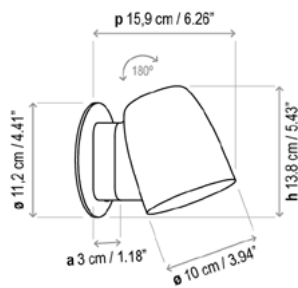
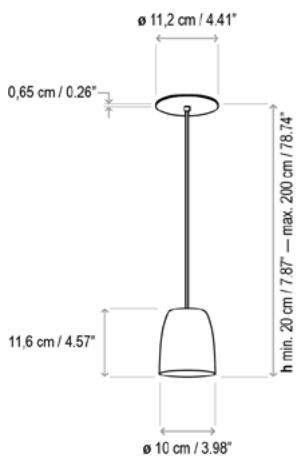



Image does not show North American backplate



Image does not show North American canopy



## Nut S/10

DRY   6,3 W LED / CRI: 90 / 2700°K  
950 lm light source / fuente de luz

## Nut A/01 Outdoor

WET    6,3 W LED / CRI: 90 / 2700°K  
950 lm light source / fuente de luz

## Nut PF/10 Outdoor

WET    6,3 W LED / CRI: 90 / 2700°K  
950 lm light source / fuente de luz





Image does not show North American backplate

**Finishes**  
*Acabados*



**Black**  
*Negro*



**White**  
*Blanco*

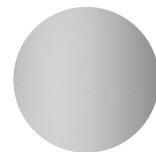

**Light grey**  
*Gris claro*

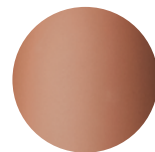

**Terracotta**  
*Teja*

**Family**  
*Familia*

A/01



PF/10



S/10







hover  
barcelona lights

---

Avda. Catalunya 173  
Polígon Ind. Sud  
08440 Cardedeu  
Barcelona, Spain

T. +34 938 713 152  
F. +34 938 462 089  
info@bover.es  
www.bover.es

1231 Collier Road,  
Suite C  
Atlanta, GA 30318  
United States

T. +1 (404) 924 2342  
info@boverusa.com  
www.boverusa.com