

cerno®



DESIGNED AND MADE IN CALIFORNIA



BELIEF

With no backyards but access to beaches and idyllic doses of salt and sun, our business story began with the adventures of three boys. Laguna Beach's creative culture and natural environment shaped our professional and aesthetic ideals. Looking back it's now clear that our childhood projects and experiments grew into our best adventure yet: building Cerno.



THE BEGINNING



Cerno founders, 1998. Left to right: Nick Sheridan, Dan Wacholder, Bret Englander.

Our drive and influences come from many different sources. One source that influenced all of us is Daniel's late grandfather, Steve. Steve grew up on a remote homestead where the existence of most objects depended on people's ability to create and fix them. For all of his 101 years, he embodied the saying "where there's a will, there's a way." On the California coast we were raised with this mentality and today we share it with the rest of the Cerno team.

CERNO

- Verb (Latin)

1. To resolve, distinguish, decide, sift, determine, to perceive.





OUR TEAM

Each finished product is a celebration of the inventive minds and industrious hands that brought it to life. Dreams do not manifest themselves; skilled people bring dreams to life. The passion of our steadily growing team and their commitment to the product is inspiring. We are grateful for every individual that is part of our collaborative creative process.

TABLE OF CONTENTS

Floor Lamps	3	Flush Mount	73
Fons 8 / 10	4	Casia 14	74
Valeo	5	Casia 18	75
Nauta	8	Casia 22	77
Altus	9	Plura	79
Forma	10	Volo	81
Silva Giant	12		
		Outdoor Sconces	83
Linear Pendants	15	Rima Outdoor	84
Lenis	17	Tersus Outdoor	86
Arca	18	Calx Outdoor	87
Camur	19	Ansa Outdoor	88
Aeris 30 / 54	21	Acuo Outdoor	89
Vix 34 / 48	23		
Vix 82	24	Vanity Lighting	91
Penna 40 / 64	25	Allavo	92
Virga	26	Merus	93
Brevis 28 / 42	27		
		Sconces	95
Pendants	29	Talea	97
Cura	31	Rima	99
Amicus 12	32	Via	100
Aminus 16	33	Calx	101
Aminus 21	35	Spero	103
Volo	37	Penna 16 / 40 / 64	104
Casia 14	38	Vesper	105
Casia 18	39	Tempus	107
Casia 22	40	Acuo	108
Abeo	41	Capio S / L	110
Spero	43	Oris	111
Cano	44	Ora	113
Bimar	45	Tersus	116
Muto	46	Sedo	117
Astrum 11	47	Ansa	119
Astrum 17	49	Fortis	120
Imber 17 / 24	50	Claudo	121
Ignis 17 / 24	52	Libri	123
Ico 20	55	Levo	125
Calx 10 / 19	56		
Calx 36	59	Table Lamps	127
Veris 12	60	Nauta	129
Veris 22	61	Forma	130
Veris 34	63		
Levis S / L	64	Revelite AL	133
Mica S / L	66		
Claudo	68	Accessories	134
Salix	69	Motus Swing Arm Bracket	134
Plura	70	Canopy Accessories	135
		Finishes & Material Options	136
		Lamping	137



Forma floor, walnut, white linen

Floor Lamps



Fons Family

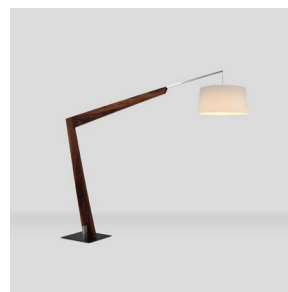

Valeo



Nauta



Altus



Forma



Silva Giant



Fons 8 / 10
floor lamp

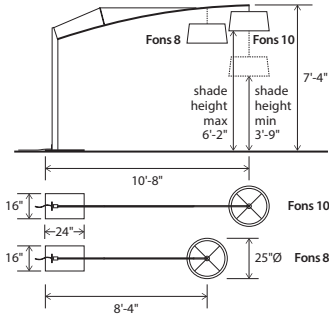

- Dimensions: 25" Ø shade, 7'-4"
- Materials: solid wood, metal, linen shade
- Product weight: 65 lb
- Light source: medium base E26 socket
- Lamping: E26 base, type A lamp, 60 W max
- Input voltage: 120 V AC max
- Includes 72" clear silver cord with inline foot switch 24" from base
- Bottom diffuser included (CM-051)
- Wood grain will vary
- Specifications subject to change
- Included dimmable LED A19 bulb
- Light output: 800 Lumens (source)
- Light color: 2700 K
- Color accuracy: 90+ CRI
- Power usage: 11 W



MATERIAL & FINISH OPTIONS

Fons part # 05-600-	
Boom Arm brushed aluminum (CM-006)	A
Wood Body walnut (CM-001)	W
Fabric Shade white linen (CM-016)	L
Arm Length 8'	E
10'	T

- Includes:*
- stainless steel tension cable (CM-053)
 - black powder coated steel base (CM-049)
 - frosted polymer diffuser (CM-051)

Alternate voltage/plug styles are available

ARM LENGTH

Available in 10'-8" and 8'-4" arm lengths
Arm length is from back of base to center of shade
Arm lengths are not adjustable

SHADE HEIGHT

Shade height (floor to bottom edge of shade) can be adjusted between 6'-2" maximum and 3'-9" minimum



walnut (CM-001)



white linen (CM-016)



The goal with the Fons was to minimize the structure and visual massing of the fixture while maximizing the reach or cantilever. The delicate boom arm, upheld by a tension cable, gently bends while reaching out to almost horizontal where it suspends the light. The structural design is an extremely effective way to resolve the forces associated with such a long reach. It is so effective and efficient that it seems to float with a weightlessness at the tip.

Nick Sheridan,
Designer

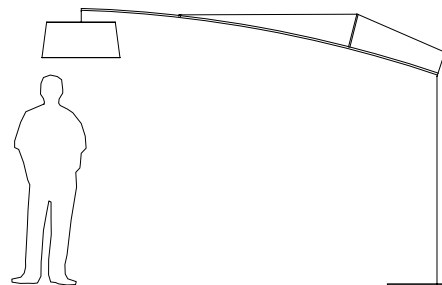



Valeo
floor lamp

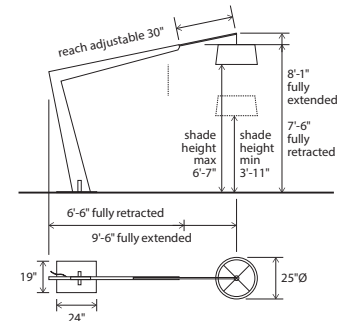

Dimensions: 8'1" H max, 25" Ø shade
 Materials: solid wood, metal, linen shade
 Product weight: 95 lb
 Light source: medium base E26 socket
 Lamping: E26 base, type A lamp, 60 W max
 Input voltage: 120 V AC max
 Includes 72" clear silver cord with inline foot switch 24" from base
 Bottom diffuser included (CM-051)
 Wood grain will vary
 Specifications subject to change
 Included dimmable LED A19 bulb
 Light output: 800 Lumens (source)
 Light color: 2700 K
 Color accuracy: 90+ CRI
 Power usage: 11 W



MATERIAL & FINISH OPTIONS

	Valeo part # 05-400-	A	L
Boom Arm			
brushed aluminum (CM-006)	A		
Wood Body			
walnut (CM-001)	W		
dark stained walnut (CM-002)	D		
white washed oak (CM-095)	O		
Fabric Shade			
white linen (CM-016)	L		

Includes:
 textured black Powder Coated base (CM-049)
 frosted polymer diffuser (CM-051)

Alternate voltage/plug styles are available

SHADE HEIGHT: Shade height (floor to bottom edge of shade) can be adjusted between 6'-7" maximum and 3'-11" minimum

ARM LENGTH: Arm length (from back of base to center of shade) can be adjusted between 9'-6" maximum and 6'-6" minimum



walnut (CM-001)



white washed oak (CM-095)



dark stained walnut (CM-002)



white linen (CM-016)

When reaching such a distance with a fixture, it is important that it feels visually efficient in its form but is still far from fragile, inviting one to linger under it. The adjustability in the reach and the height of the shade make it possible to custom fit the piece to its surroundings - an important characteristic for such a large piece.

Nick Sheridan,
Designer

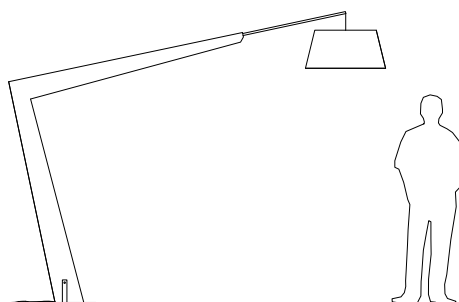



Valeo, walnut, white linen



Nauta
 floor lamp

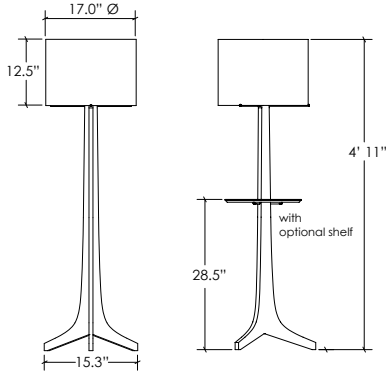

Dimensions: 17" Ø shade, 4'11"
 Materials: solid wood, aluminum, fabric shade
 Product weight: 8 lb
 Light source: medium base E26 socket
 Lamping: E26 base, 60 W max
 Input voltage: 250 V AC max
 Includes 8' clear silver cord with white plug
 On/Off rocker switch on socket
 Wood grain will vary
 Specifications subject to change
 Included dimmable LED A19 bulb
 Light output: 800 Lumens (source)
 Light color: 2700 K
 Color accuracy: 90+ CRI
 Power usage: 11 W



white washed oak, brushed brass, burlap



brushed aluminum (CM-006)

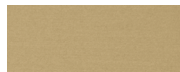

brushed brass (CM-120)



walnut (CM-001)

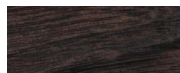

dark stained walnut (CM-002)



white washed oak (CM-095)



black amaretto (CM-018)



white linen (CM-016)



burlap (CM-017)

MATERIAL & FINISH OPTIONS

Nauta floor part #: 05-110-

Metal Finish

- brushed aluminum (CM-006) A
- brushed brass (CM-120) R

Wood Body

- walnut (CM-001) W
- dark stained walnut (CM-002) D
- white washed oak (CM-095) O

Fabric Shade

- black amaretto (CM-018) A
- white linen (CM-016) L
- burlap (CM-017) N

Optional Shelf Accessory

- no shelf N
- matching wood shelf -
exposed wood top surface M
- matching wood shelf -
black HPL top surface (CM-092) B
- matching wood shelf -
white HPL top surface (CM-093) W

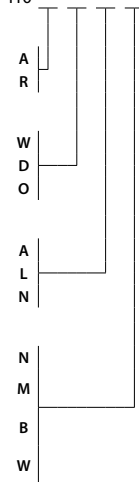

walnut, brushed aluminum, white linen



walnut, brushed brass, black amaretto



walnut, brushed aluminum, burlap, walnut shelf

Efficiency and simplicity guided the design process for the Nauta table lamp. We designed the Forma several years ago with Frank Carfaro of Desiron, which profoundly influenced the Nauta's form. Our goal was to distill the Forma design without compromising it. The Nauta is clean, modern, and priced competitively.

Nick Sheridan,
 Designer

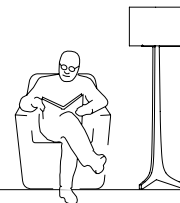

Altus
 floor lamp



walnut, distressed brass, white linen

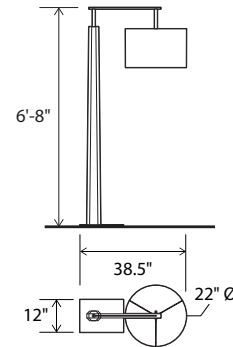

Dimensions: 6'-8" H, 22" Ø shade
 Materials: solid wood, metal, fabric shade
 Product weight: 45 lb
 Light source: medium base E26 socket
 Lamping: E26 base, type A lamp, 60 W max
 120 V AC max
 Dimmable on fixture
 Wood grain will vary
 Specifications subject to change
 Included dimmable LED A19 bulb
 Light output: 800 Lumens (source)
 Light color: 2700 K
 Color accuracy: 90+ CRI
 Power usage: 11 WW



MATERIAL & FINISH OPTIONS

Altus part # 05-700-

Metal Finish

- brushed brass (CM-008) R
- distressed brass (CM-009) D
- oiled bronze (CM-010) Z

Wood Body

- walnut (CM-001) W
- dark stained walnut (CM-002) D

Fabric Shade

- burlap (CM-017) N
- white linen (CM-016) L
- black amaretto (CM-018) A

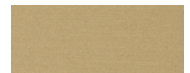

brushed brass (CM-008)



distressed brass (CM-009)



oiled bronze (CM-010)



walnut (CM-001)



dark stained walnut (CM-002)



black amaretto (CM-018)



white linen (CM-016)



burlap (CM-017)

Alternate voltage/plug styles are available



brushed brass top detail

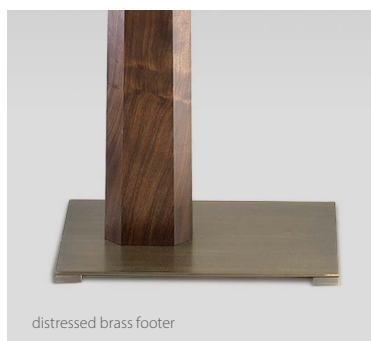

distressed brass footer

The Altus is a robust fixture that also carries an air of elegance and subtle proportion. It has the mass and impact to anchor a space while still showing balance and grace. It is always exciting to see how the solid wood trunk comes out; admiring the wood grain all the way through.

Nick Sheridan,
 Co-Designer

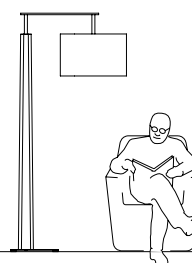

Forma
 floor lamp

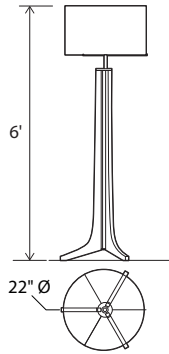

Dimensions: 22" Ø shade, 6'0"
 Materials: solid wood, aluminum, fabric shade
 Product weight: 15 lb
 Light source: medium base E26 socket
 Lamping: E26 base, type A lamp, 60 W max
 Input voltage: 120 V AC max
 Dimmable on fixture
 Wood grain will vary
 Specifications subject to change
 Included dimmable LED A19 bulb
 Light output: 800 Lumens (source)
 Light color: 2700 K
 Color accuracy: 90+ CRI
 Power usage: 11 W



MATERIAL & FINISH OPTIONS

Forma floor part #: 05-300-

<i>Metal Finish</i>		
brushed aluminum (CM-006)	A	
black anodized aluminum (CM-007)	B	
<i>Wood Body</i>		
walnut (CM-001)	W	
dark stained walnut (CM-002)	D	
maple (CM-005)	M	
<i>Fabric Shade</i>		
black amaretto (CM-018)	A	
white linen (CM-016)	L	
burlap (CM-017)	N	

Alternate voltage / plug styles are available



brushed aluminum (CM-006)



black anodized aluminum (CM-007)



walnut (CM-001)

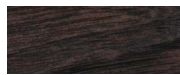

dark stained walnut (CM-002)



maple (CM-005)



black amaretto (CM-018)



white linen (CM-016)



burlap (CM-017)



brushed aluminum, walnut, burlap



black anodized aluminum, dark stained walnut, white linen



black anodized aluminum, walnut, black amaretto

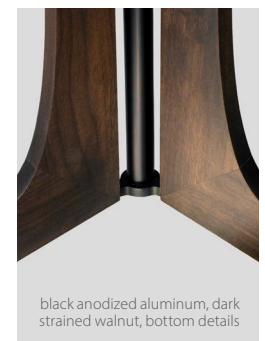

black anodized aluminum, dark stained walnut, bottom details

Frank Carfaro and I worked to design a piece that embraced both Cerno and Desiron's aesthetic, without deviating too much from either brand's design language. I am really pleased with the fluidity, posture and scale we achieved with the Forma.

*Nick Sheridan,
 Co-Designer*

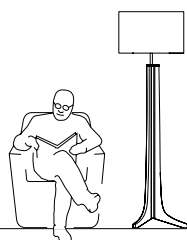



Forma floor, black anodized aluminum, dark stained walnut, black amaretto

Silva Giant
floor lamp

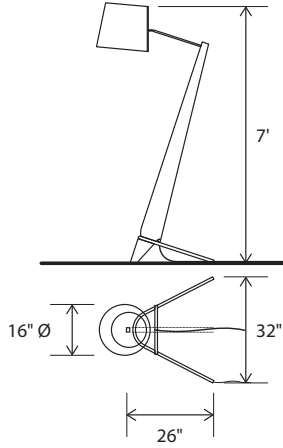

Dimensions: 32" x 26", 7', 16" Ø shade
 Materials: solid wood, aluminum, fabric shade
 Product weight: 60 lb
 Light source: medium base E26 socket
 Lamping: E26 base, type A lamp, 60 W max
 Input voltage: 120 V AC max
 Includes 72" clear silver cord with inline foot
 switch 24" from base
 Bottom diffuser included (CM-057)
 Wood grain will vary
 Specifications subject to change
 Included dimmable LED A19 bulb
 Light output: 800 Lumens (source)
 Light color: 2700 K
 Color accuracy: 90+ CRI
 Power usage: 11 W



MATERIAL & FINISH OPTIONS

Silva Giant part #: 05-200-

Metal Finish		
brushed aluminum (CM-006)	A	
Wood Body		
walnut (CM-001)	W	
dark stained walnut (CM-002)	D	
Fabric Shade		
white linen (CM-058)	L	



brushed aluminum (CM-006)



walnut (CM-001)



dark stained walnut (CM-002)



white linen (CM-058)



brushed aluminum, walnut, white linen



shade details



bottom details

The Silva Giant, as the name suggests, is a giant version of our Silva table fixture. Its scale gives it a strong presence even in very large spaces, while its distilled form gives it a simplicity that can be seen from across the room. A fun piece with a huge personality.

Nick Sheridan,
Designer

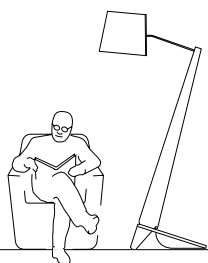





Penna linear pendant, brushed brass, walnut

Linear Pendants



Lenis

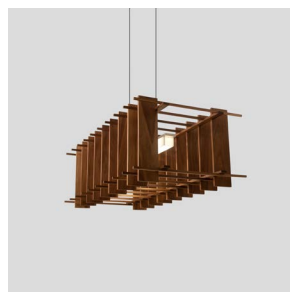

Arca

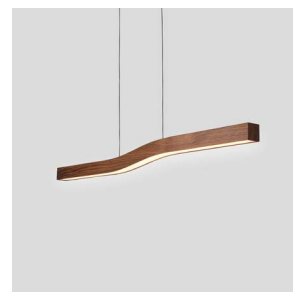

Camur



Aeris



Vix

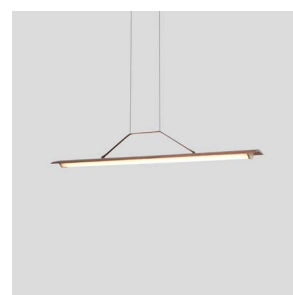

Penna

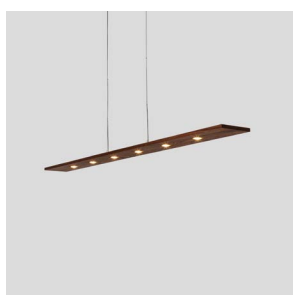

Vix 82



Virga



Brevis





Lenis linear pendant

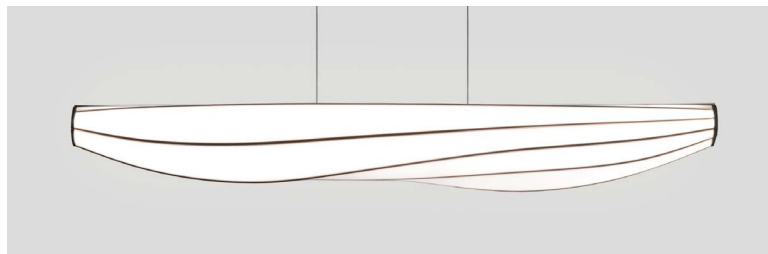

Bret, Dan and I have always loved the ocean and boats. In fact, the first project we built together as young boys was a sailboat. Our appreciation for the beauty of a well-designed craft is what initially inspired the Lenis fixture; the form is created by bending wood stringers over a series of bulkheads. The organic and sculptural structure deviates from our mostly rectilinear forms, which introduced many new challenges, yet it also breathed new life into the design process for us. Ultimately, we were searching for that balance between the curved fluidity of its lines and the twisting movement. Thanks to our team's determination, after countless studies and prototypes, we found the balance we were looking for.

Nick Sheridan,
Designer

Lenis

linear pendant

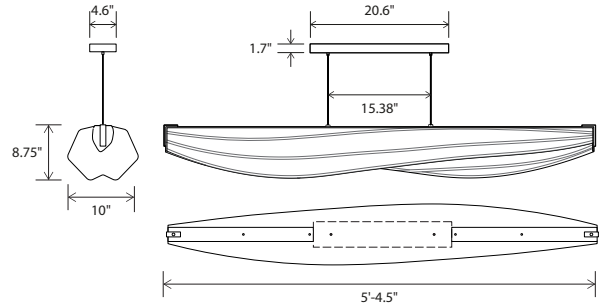

Dimensions: 64.5" x 10", 8.75"
 Materials: aluminum, stretch fabric
 Product weight: 10 lb
 Light source: integrated LED
 Light output: 5000 Lumens (source)
 Light color*: 2700 K or 3500 K
 Color accuracy: 90+ CRI
 Power usage: 70 W
 Dimmable (see driver below)
 Brushed Aluminum (CM-006) linear canopy included
 Canopy dimensions: 20.6" x 4.6", 1.7"
 Wood canopy covers are available:
 Walnut (CM-001) cover: part # 60-130-005W
 Dark stained walnut (CM-002) cover: part # 60-130-005D
 See website for more canopy information
 6'-0" drop length, field adjustable
 Suitable for a sloped ceiling
 Wood grain will vary
 Specifications subject to change
 Patent # USD857968S1

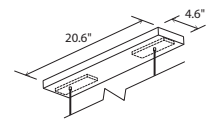

brushed aluminum linear canopy



brushed aluminum (CM-006)



walnut (CM-001)



dark stained walnut (CM-002)

MATERIAL & FINISH OPTIONS

Lenis part # 07-220-

Shade	white fabric stretch (CM-079)	L
End Detail	brushed aluminum (CM-006)	A
	dark stained walnut (CM-002)	D
	walnut (CM-001)	W
Lamping	2700 K LED	27
	3500 K LED	35
Driver	120 V AC input voltage	P1
	TRIAC, ELV & 0-10 V dimming	
	277 V AC input voltage	P2
	TRIAC, ELV & 0-10 V dimming	

Includes: brushed aluminum (CM-006)

*Available in 3000K, 4000K and other color temperatures upon request

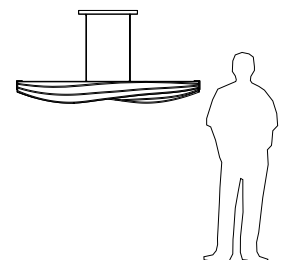

Arca
linear pendant

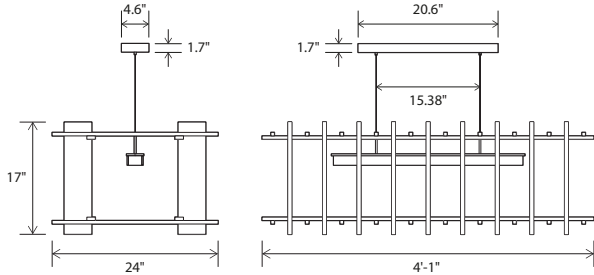

Dimensions: 4'1" x 24", 17"
 Materials: solid wood, aluminum, polymer
 Product weight: 20 lb
 Light source: integrated LED
 Light output: 1720 Lumens (source)
 Light color: 2700 K or 3500 K
 Color accuracy: 90+ CRI
 Power usage: 16 W
 Dimmable (see driver below)
 Linear canopy included
 Canopy dimensions: 20.6" x 4.6", 1.7"
 Canopy finish matches fixture's metal finish
 Wood canopy covers are available:
 Walnut (CM-001) cover: part # 60-130-005W
 Dark stained walnut (CM-002) cover:
 part # 60-130-005D
 See website for more canopy information
 6'-0" drop length, field adjustable
 Suitable for a sloped ceiling
 Wood grain will vary
 Specifications subject to change

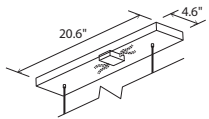

brushed aluminum linear canopy



brushed aluminum (CM-006)



black anodized aluminum (CM-007)



walnut (CM-001)



dark stained walnut (CM-002)

MATERIAL & FINISH OPTIONS

Arca part #: 07-120-

Metal Finish		
brushed aluminum (CM-006)	A	
black anodized aluminum (CM-007)	B	
Wood Body		
walnut (CM-001)	W	
dark stained walnut (CM-002)	D	
Lamping		
2700 K LED	27	
3500 K LED	35	
Driver		
AC Input Voltage Range: 120-277 V		
120 V input:		
TRIAC, ELV & 0-10 V dimmable	P1	
240 & 277 V input: only 0-10 V dimmable		

Includes:
 white polymer shade (CM-052)
 frosted polymer diffuser (CM-024)
 *Available in 3000K, 4000K and other color temperatures upon request

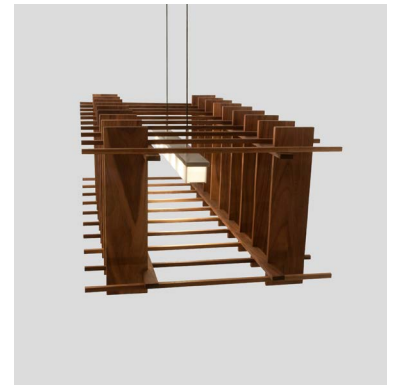
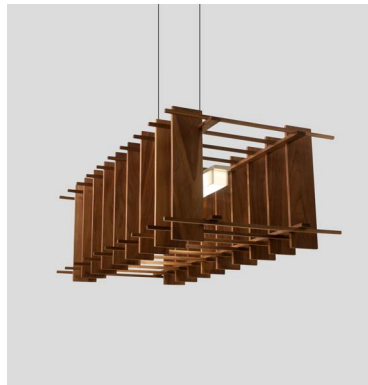

The Arca is an experiment with density and mass. As one moves around the room, the fixture morphs from a commanding presence of solid walnut into a graceful bar of light surrounded by an elegant porous cage.

Nick Sheridan,
Designer

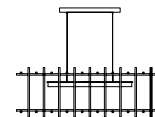

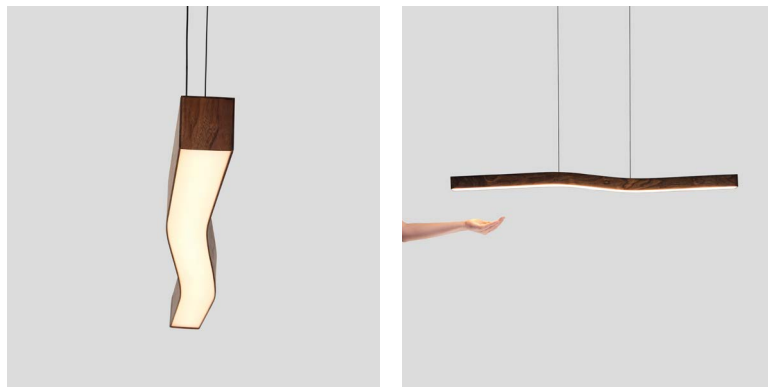

Light and delicate, subtly unique while simple, the camur must be experienced to really be appreciated. The gentle curve appears from the bottom just the same as it does from the side: but the perspectives found between the two intrigue.

Nick Sheridan,
Designer

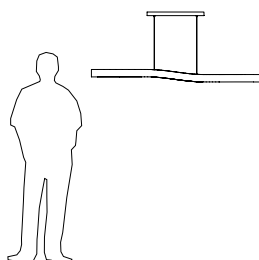

Camur linear pendant

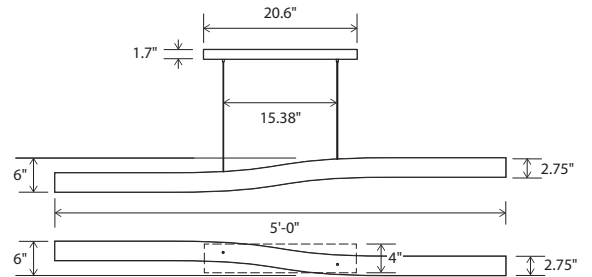

Dimensions: 5'0" x 2.75", 2.75"
 Materials: solid wood, polymer
 Product weight: 6 lb
 Light source: integrated LED
 Light output: 2500 Lumens (source)
 Light color: 2700 K or 3500 K
 Color accuracy: 90+ CRI
 Power usage: 35 W
 Dimmable (see driver below)
 Brushed aluminum (CM-006) camur canopy included
 Canopy dimensions: 20.6" x 4.6", 1.7"
 Wood camur canopy covers are available:
 Walnut (CM-001) wood camur canopy cover: part # 60-150-005W
 Dark stained walnut (CM-002) wood camur canopy cover: part # 60-150-005D
 See website for more canopy information
 6'-0" drop length, field adjustable
 Suitable for a sloped ceiling
 Wood grain will vary
 Specifications subject to change

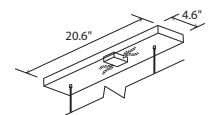

brushed aluminum linear canopy



walnut linear canopy



walnut (CM-001)

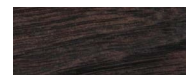

dark stained walnut (CM-002)

MATERIAL & FINISH OPTIONS

Camur part # 07-210-		
Wood Body		
walnut (CM-001)	W	
dark stained walnut (CM-002)	D	
Lamping		
2700 K LED	27	
3500 K LED	35	
Driver		
120 V AC input voltage	P1	
TRIAC, ELV & 0-10 V dimming		
277 V AC input voltage	P2	
TRIAC, ELV & 0-10 V dimming		

*Available in 3000K, 4000K and other color temperatures upon request.

The true beauty of the Camur is difficult to appreciate in print. When experiencing this fixture in person you begin to see the subtlety and grace of its vertical and horizontal movements. As you walk around this fixture the shape will morph from a beautiful curve to a straight line. We have created a video to help celebrate these details at www.cernogroup.com/camur.



Aeris, brushed aluminum, walnut

Aeris 30 / 54
linear pendant

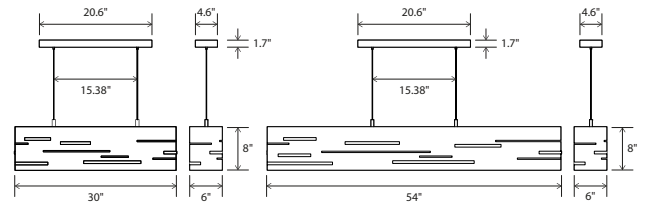

Aeris 30 dimensions: 30" x 6", 8"
Aeris 54 dimensions: 54" x 6", 8"
Materials: solid wood, aluminum
Aeris 30 weight: 11 lb
Aeris 54 weight: 15 lb
Light source: integrated LED
Light output - total: 1720 Lumens (source)
Light output - downlight: 1030 Lumens (source)
Light output - uplight: 690 Lumens (source)
Light color: 2700 K or 3500 K
Color accuracy: 90+ CRI
Power usage: 16 W
Dimmable (see driver below)
Linear canopy included
Canopy dimensions: 20.6" x 4.6", 1.7"
Canopy finish matches fixture's metal finish
Wood canopy covers are available:
Walnut (CM-001) cover: part #60-130-005W
Dark stained walnut (CM-002) cover: part #60-130-005D
See website for more canopy information
6'-0" drop length, field adjustable
Suitable for a sloped ceiling
Wood grain will vary
Specifications subject to change

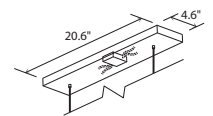

brushed aluminum linear canopy



walnut linear canopy



brushed aluminum (CM-006)



black anodized aluminum (CM-007)



walnut (CM-001)



dark stained walnut (CM-002)

MATERIAL & FINISH OPTIONS

	Aeris part # 07-
Aeris 30	110
Aeris 54	100
Metal Finish	
brushed aluminum (CM-006)	A
black anodized aluminum (CM-007)	B
Wood Body	
walnut (CM-001)	W
dark stained walnut (CM-002)	D
Lamping	
2700 K LED	27
3500 K LED	35
Driver	
AC Input Voltage Range: 120-277 V	
120 V input:	
TRIAC, ELV & 0-10 V dimmable	P1
240 & 277 V input:	
only 0-10 V dimmable	

Includes: polymer shade (CM-052)

*Available in 3000K, 4000K and other color temperatures upon request



walnut



dark stained walnut



walnut

The Aeris was a collaboration with New York based designer Frank Carfaro of Desiron. The organic and often wild swirls of walnut grain are interrupted by rigorous slits and inlays that punctuate each face to create a beautiful juxtaposition, making each fixture unique. The glow of the illuminated wood seen through the cut slits creates a rich composition of light and shadow.

Nick Sheridan,
Co-Designer

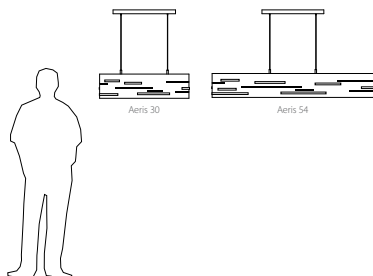



Vix linear pendant, walnut

Vix 34 / 48
linear pendant



white washed oak



walnut, above view



walnut

A clean, modern fixture finely executed. With multiple down and up lights, the Vix provides lots of usable light in a very unobtrusive design.

Nick Sheridan,
Designer

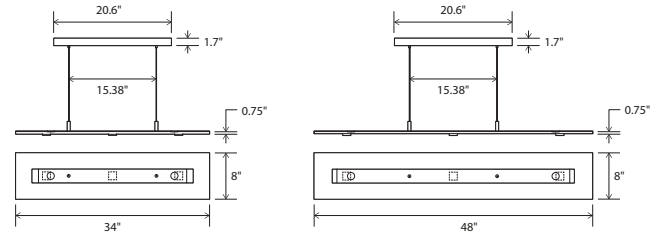
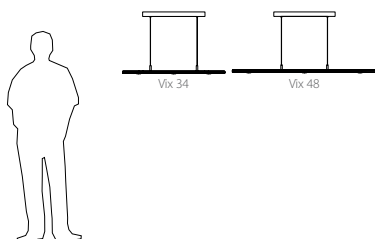

Vix 34 dimensions: 34" x 8" , 0.75"

Vix 48 dimensions: 48" x 8" , 0.75"

Materials: solid wood, polymer, aluminum

Vix 34 weight: 10 lb

Vix 48 weight: 15 lb

Light source: integrated LED

Light output - total: 1720 Lumens (source)

Light output - downlight: 1030 Lumens (source)

Light output - uplight: 690 Lumens (source)

Light color*: 2700 K or 3500 K

Color accuracy: 90+ CRI

Power usage: 16 W

Dimmable (see driver below)

Brushed aluminum (CM-006) linear canopy included

Canopy dimensions: 20.6" x 4.6", 1.7"

Wood canopy cover available:

Walnut (CM-001) cover: part # 60-130-005W

Dark stained walnut (CM-002) cover: part # 60-130-005D

See website for more canopy information

6'-0" drop length, field adjustable

Suitable for a sloped ceiling

Wood grain will vary

Wood shade may slightly bow or twist

Specifications subject to change

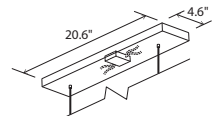

brushed aluminum linear canopy

MATERIAL & FINISH OPTIONS

Vix part # 07-	
Vix 34	140
Vix 48	130
Wood Body	
walnut (CM-001)	W
dark stained walnut (CM-002)	D
white washed oak (CM-095)	O
Lamping*	
2700 K LED	27
3500 K LED	35
Driver	
AC Input Voltage Range: 120-277 V	
120 V input: TRIAC, ELV & 0-10 V dimmable	P1
240 & 277 V input: only 0-10 V dimmable	



walnut (CM-001)



dark stained walnut (CM-002)



white washed oak (CM-095)

Includes: polymer shade (CM-052)

*Available in 3000K, 4000K and other color temperatures upon request

Vix 82
linear pendant

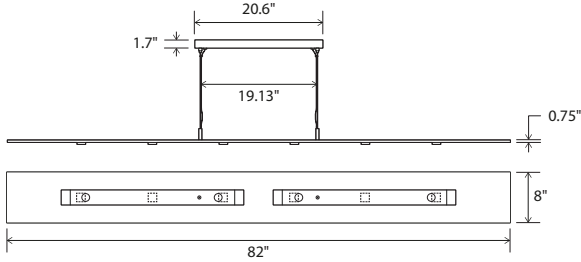

- Dimensions: 82" x 8", 0.75"
- Materials: solid wood, polymer, aluminum
- Product weight: 19 lb
- Light source: integrated LED
- Light output - total: 3440 Lumens (source)
- Light output - downlight: 2060 Lumens (source)
- Light output - uplight: 1380 Lumens (source)
- Light color*: 2700 K or 3500 K
- Color accuracy: 90+ CRI
- Power usage: 32 W
- Dimmable (see driver below)
- Brushed aluminum (CM-006) linear canopy included
- Canopy dimensions: 20.6" x 4.6", 1.7"
- See website for more canopy information
- Drop length field adjustable: 0'-10" min, 8'-0" max
- Suitable for a sloped ceiling
- Wood grain will vary
- Wood shade may slightly bow or twist along 82" length
- Specifications subject to change

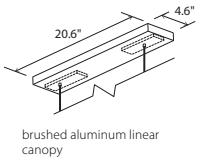

MATERIAL & FINISH OPTIONS

Vix 82 part #: 07-200-

Wood Body	
walnut (CM-001)	W
dark stained walnut (CM-002)	D
white washed oak (CM-095)	O
Lamping	
2700 K LED	27
3500 K LED	35
Driver	
AC Input Voltage Range: 120-277 V	
120 V input:	
TRIAC, ELV & 0-10 V dimmable	P1
240 & 277 V input:	
only 0-10 V dimmable	

Includes: white polymer shade (CM-052)

*Available in 3000K, 4000K and other color temperatures upon request

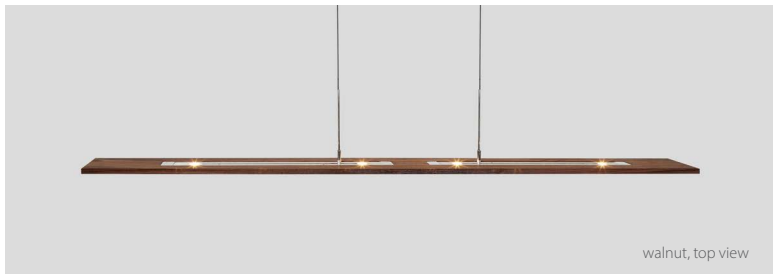

A clean, modern fixture finely executed. With multiple down and up lights, the Vix provides lots of usable light in a very unobtrusive design.

Nick Sheridan,
Designer

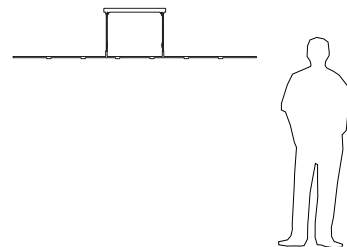

Penna 40 / 64
linear pendant



distressed brass, dark stained walnut



brushed brass, white washed oak



distressed brass, walnut, under detail

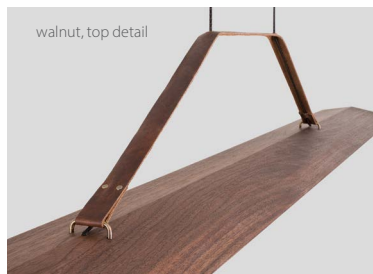

walnut, top detail

On our Cerno journey, we continue to evolve as designers and craftsman. The Penna is a celebration of us drawing and reflecting on our last ten years. This design is an embodiment of all the lessons that we have learned from designing and building thousands of lights. This fixture balances utility and sophisticated beauty well. The walnut, brass, and leather work in concert to compose a modern form with materials that have been used for thousands of years.

Nick Sheridan,
Designer

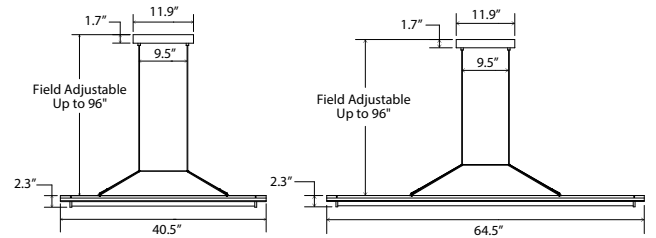
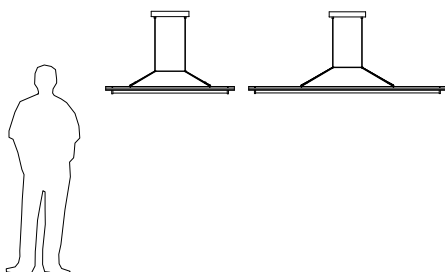

Penna 40 dimensions: 40.5" x 7.7" , 2.3"

Penna 64 dimensions: 64.5" x 7.7" , 2.3"

Penna 40 weight: 7 lb

Penna 64 weight: 10 lb

Light source: integrated LED

Penna 40 light output: 1530 Lumens (source)

Penna 64 light output: 2550 Lumens (source)

Light color*: 2700 K or 3500 K

Color accuracy: 90+ CRI

Penna 40 power usage: 21 W

Penna 64 power usage: 35 W

Dimmable (see driver below)

Linear canopy included

Canopy dimensions: 11.9" x 4.4", 1.7"

Canopy finish: matte black (CM-085)

See website for more canopy information

8'-0" drop length, field adjustable

Suitable for a sloped ceiling

Wood grain will vary

Specifications subject to change

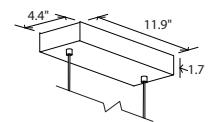

matte black linear canopy



MATERIAL & FINISH OPTIONS

Penna pendant part #	07-150-	B	-	-
Size	40"	40		
	64"	64		
Metal Finish	brushed brass (CM-120)	R		
	distressed brass (CM-117)	D		
Wood Body	walnut (CM-001)	W		
	dark stained walnut (CM-002)	D		
	white washed oak (CM-095)	O		
Lamping	2700 K LED	27		
	3500 K LED	35		
Driver	120 V AC input voltage TRIAC, ELV & 0-10 V dimming	P1		
	277 V AC input voltage TRIAC, ELV & 0-10 V dimming	P2		



brushed brass (CM-120)



distressed brass (CM-117)



walnut (CM-001)



dark stained walnut (CM-002)



white washed oak (CM-095)

Includes:

brown leather (CM-098)

frosted polymer (CM-057)

*Available in 3000K, 4000K and other color temperatures upon request

Virga
linear pendant

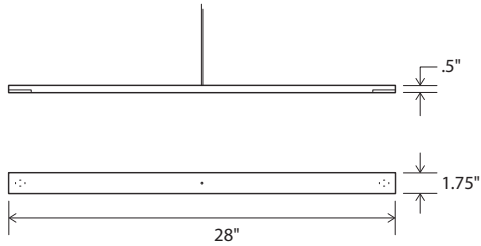

Dimensions: 28" x 1.75" , 0.5"
 Materials: aluminum, polymer
 Product weight: 6 lb
 Light source: integrated LED
 Light output: 1126 Lumens (source)
 Light color*: 2700 K or 3500 K
 Color accuracy: 90+ CRI
 Power usage: 13 W
 Dimmable (see driver below)
 Extended-profile square canopy included,
 required to house LED driver
 (3.25" x 2.25" x 1.25")
 Canopy dimensions: 4.5" x 4.5", 1.38"
 Canopy finishes Brushed Aluminum (CM-006)
 and Textured Black (CM-049)
 See website for more canopy information
 48" suspension tube (can be shortened in field)
 Swivel option available for sloped ceilings,
 see drawing below
 Specifications subject to change

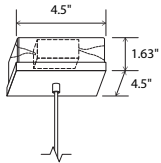

brushed aluminum square
extended canopy



walnut (CM-001)



flat black (CM-030)

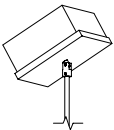

sloped extended-profile square
canopy

MATERIAL & FINISH OPTIONS

Virga part #: 06-130-

Metal Finish	
brushed aluminum (CM-006)	A
flat black (CM-0030)	B
Lamping	
2700 K LED	27
3500 K LED	35
Driver	
AC Input Voltage Range: 120-277 V	
120 V input: TRIAC, ELV & 0-10 V dimmable	P1
240 & 277 V input: only 0-10 V dimmable	

Includes: white polymer shade (CM-052)

Available for sloped ceilings

Sloped extended-profile square canopy

*Available in 3000K, 4000K and other color temperatures upon request



flat black



brushed aluminum

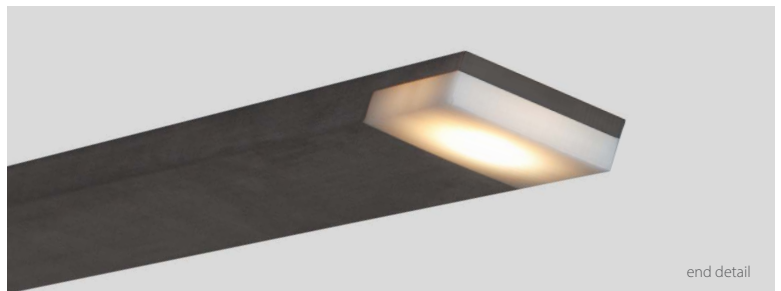

end detail

A clean, minimal fixture executed without compromise. The very simple and sleek down light bar can be installed in very close proximity to its user - and withstand close scrutiny.

Nick Sheridan,
Designer

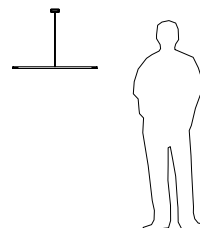

Brevis 28 / 42
linear pendant

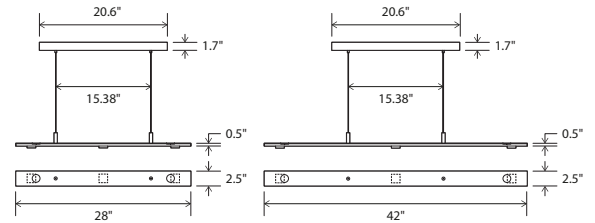

Brevis 28 dimensions: 28" x 2.5" , 0.5"

Brevis 42 dimensions: 42" x 2.5" , 0.5"

Materials: aluminum, polymer

Brevis 28 weight: 7 lb

Brevis 42 weight: 8 lb

Light source: integrated LED

Light output - total: 1720 Lumens (source)

Light output - downlight: 1030 Lumens (source)

Light output - uplight: 690 Lumens (source)

Light color*: 2700 K or 3500 K

Color accuracy: 90+ CRI

Power usage: 16 W

Dimmable (see driver below)

Linear canopy included

Canopy dimensions: 20.6" x 4.6", 1.7"

Canopy finish matches fixture's metal finish

Wood canopy covers are available:

Walnut (CM-001) cover: part # 60-130-005W

Dark stained walnut (CM-002) cover: part # 60-130-005D

See website for more canopy information

6'-0" drop length, field adjustable

Suitable for a sloped ceiling

Specifications subject to change

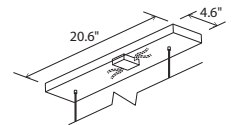

brushed aluminum linear canopy



MATERIAL & FINISH OPTIONS

Brevis part # 06-

Brevis 28	920			
Brevis 42	910			
Metal Finish				
brushed aluminum (CM-006)	A			
black anodized aluminum (CM-007)	B			
Lamping				
2700 K LED	27			
3500 K LED	35			
Driver				
AC Input Voltage Range: 120-277 V	P1			
120 V input:				
TRIAC, ELV & 0-10 V dimmable				
240 & 277 V input: only 0-10 V dimmable				



brushed aluminum (CM-006)



black anodized aluminum (CM-007)

Includes: polymer shade (CM-052)

*Available in 3000K, 4000K and other color temperatures upon request



Brevis 42, brushed aluminum



Brevis 28, brushed aluminum



Brevis 28, brushed aluminum, close detail

A clean, minimal fixture finely executed. With multiple down and up lights, the Brevis provides lots of usable light in a very unobtrusive design.

Nick Sheridan,
Designer

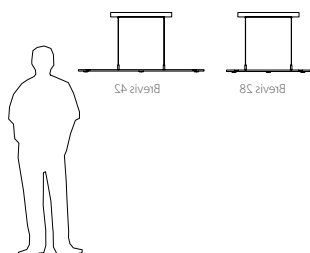



Pendants



Amicus 12, 16, 21

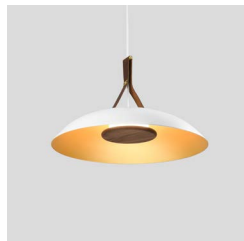

Volo



Casia 14, 18, 22

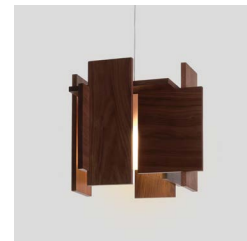

Abeo

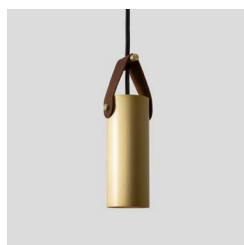

Spero

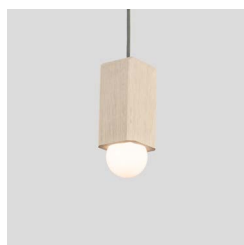

Cano

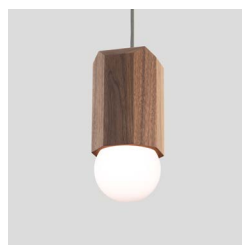

Bimar

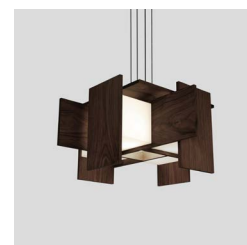

Muto



Astrum 11, 17



Imber



Ignis



Ico

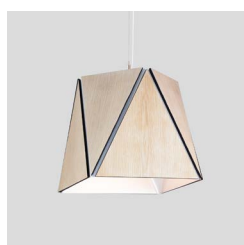

Calx 10, 19, 36

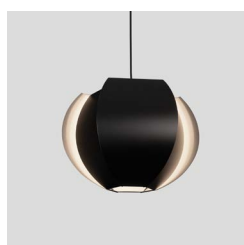

Veris 12, 22, 34



Levis S, L



Mica S, L

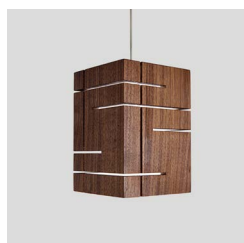

Clauco



Salix



Plura



Cura pendant, raw walnut

Cura
pendant



raw walnut

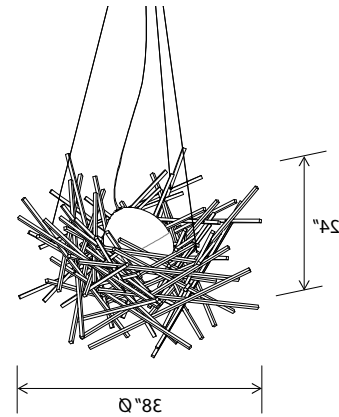

Dimensions: 38" Ø, 24"
 Materials: solid wood, paper mache
 Product weight: 12 lb
 Light source: LED, candelabra base E12 socket
 Light output: 950 Lumens (source)
 Light color: 2700K or 3000K
 Color accuracy: 90+ CRI
 Input Voltage: 100-130 V AC
 Round canopy with clear SPT wire
 and stainless steel suspension cables
 See technical specifications for
 more canopy information
 96" max drop length, field adjustable
 Wood grain will vary
 Specifications subject to change



MATERIAL & FINISH OPTIONS

Cura pendant part #: 06-230-

Wood Body

raw walnut (CM-130)
 raw white oak (CM-131)

Canopy

textured white (CM-060)
 textured black (CM-049)

Lamping

2700 K LED
 3000 K LED

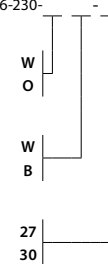

raw walnut (CM-130)



raw white oak (CM-131)

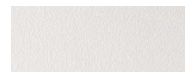

textured white (CM-060)



textured black (CM-049)



raw walnut



The intricacy, integrity, and architecture of nests found in the wild are breathtaking and what ultimately inspired the Cura. Nests embody resourcefulness and innovation. Like human homes, nests protect our most precious and sacred creations, our offspring.

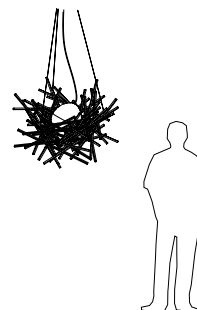

Amicus 12 pendant

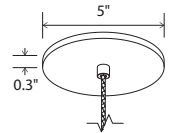
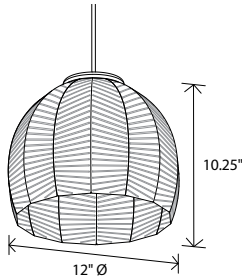

low-profile round canopy with SVT-3 cable



brushed brass (CM-047)



distressed brass (CM-096)



brushed aluminum (CM-012)



brushed rose gold (CM-046)



black powder coat (CM-049)

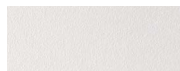

white powder coat (CM-060)



walnut (CM-001)

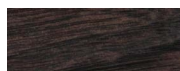

dark stained walnut (CM-002)



white washed oak (CM-095)

Dimensions: 12" Ø, 10.25"
 Product weight: 3 lb
 Suitable for a sloped ceiling
Integrated LED Specifications
 Light Color Options:
 2700 K - 831 Lumens (source)
 3500 K - 873 Lumens (source)
 Color accuracy: 90+ CRI
 Power usage: 10 W
 Dimmable (see power options below)
 JA8-2019 Compliant

E26 Medium Base Specifications
 Lamping: E26 base, 60 W max,
 G40 recommended
 Bulb not included
 Input voltage: 250 V AC max

Textured Black Powder Coat (CM-049)
 low profile round canopy with
 SVT-3 Cable, Black (CM-039)
 Canopy dimensions: 5" Ø, 0.3"
 See website for more canopy information
 Field adjustable drop length:
 0'6" min - 8'0" max
 Wood grain will vary
 Specifications subject to change
 Suitable for dry or damp locations



MATERIAL & FINISH OPTIONS

Amicus 12 part #: 06-290-12

Metal Shade		
brushed brass (CM-047)	R	
distressed brass (CM-096)	D	
brushed aluminum (CM-012)	A	
brushed rose gold (CM-046)	G	
black powder coat (CM-049)	B	
white powder coat (CM-060)	W	
Wood Top		
walnut (CM-001)	W	
dark stained walnut (CM-002)	D	
white washed oak (CM-095)	O	
Lamping		
2700 K LED	27	
3500 K LED	35	
medium base E26 socket	MB	
Power Option (LED version only)		
120-277 V AC input voltage		
TRIAC and ELV dimming	P1	

*Available in 3000K, 4000K and other color temperatures upon request



brushed brass

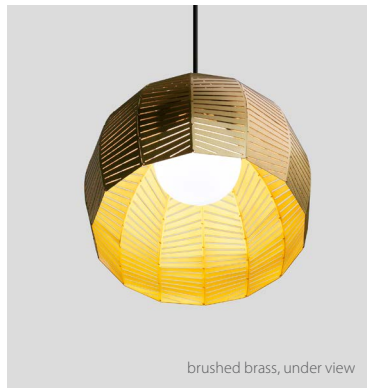

brushed brass, under view

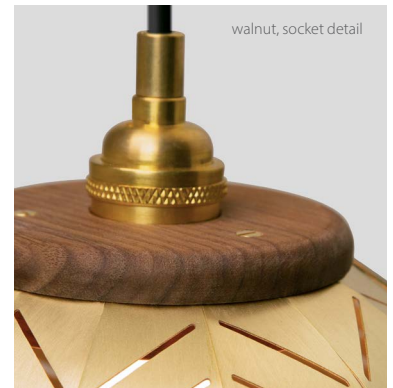

walnut, socket detail

Traveling through Morocco, I was in awe of the skilled craftspeople and their impressive work. I was most enamored with the detail and intricacy of the perforated metal light fixtures. The artistry, patterns, and old-world techniques inspired me and ultimately inspired the Amicus.

Nick Sheridan,
Designer

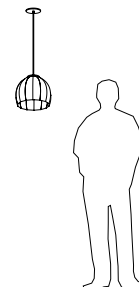



brushed brass



black powder coat



white washed oak,
integrated LED top detail

Traveling through Morocco, I was in awe of the skilled craftspeople and their impressive work. I was most enamored with the detail and intricacy of the perforated metal light fixtures. The artistry, patterns, and old-world techniques inspired me and ultimately inspired the Amicus.

Nick Sheridan,
Designer

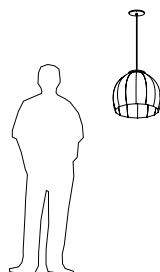

Aminus 16 pendant

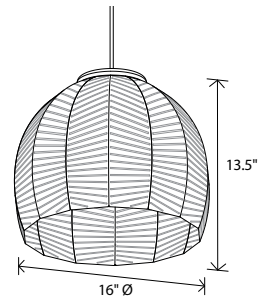

Dimensions: 15.8" Ø, 13.5"
Product weight: 4 lb
Suitable for a sloped ceiling

Integrated LED Specifications

Light Color Options:
2700 K - 831 Lumens (source)
3500 K - 873 Lumens (source)
Color accuracy: 90+ CRI
Power usage: 10 W
Dimmable (see power options below)
JA8-2019 Compliant

E26 Medium Base Specifications

Lamping: E26 base, 60 W max,
G40 recommended
Bulb not included
Input voltage: 250 V AC max

Textured Black Powder Coat (CM-049) low profile
round canopy with SVT-3 Cable, Black (CM-039)
Canopy dimensions: 5" Ø, 0.3"

See website for more canopy information
Field adjustable drop length: 0'6" min - 8'0" max
Wood grain will vary
Specifications subject to change
Suitable for dry or damp locations



MATERIAL & FINISH OPTIONS

Amicus 16 part # 06-290-16-

Metal Shade

brushed brass (CM-047)
distressed brass (CM-096)
brushed aluminum (CM-012)
brushed rose gold (CM-046)
black powder coat (CM-049)
white powder coat (CM-060)

Wood Top

walnut (CM-001)
dark stained walnut (CM-002)
white washed oak (CM-095)

Lamping

2700 K LED
3500 K LED
medium base E26 socket

Power Option (LED version only)

120-277 V AC input voltage
TRIAC and ELV dimming

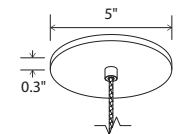
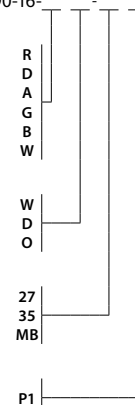

black low-profile round canopy
with SVT-3 cable



brushed brass (CM-047)



distressed brass (CM-096)



brushed aluminum (CM-012)



brushed rose gold (CM-046)



black powder coat (CM-049)

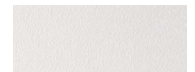

white powder coat (CM-060)



walnut (CM-001)



dark stained walnut (CM-002)



white washed oak (CM-095)

*Available in 3000K, 4000K and other color
temperatures upon request



Amicus, brushed brass



brushed brass



brushed brass, under view



walnut, socket top detail

Traveling through Morocco, I was in awe of the skilled craftspeople and their impressive work. I was most enamored with the detail and intricacy of the perforated metal light fixtures. The artistry, patterns, and old-world techniques inspired me and ultimately inspired the Amicus.

Nick Sheridan,
Designer

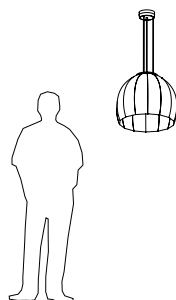

Aminus 21 pendant

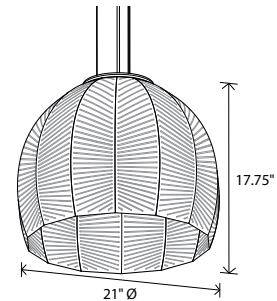

Dimensions: 21" Ø, 17.75"
Product weight: 6 lb
Suitable for a sloped ceiling
Integrated LED Specifications
Light Color Options:
2700 K - 831 Lumens (source)
3500 K - 873 Lumens (source)
Color accuracy: 90+ CRI
Power usage: 10 W
Dimmable (see power options below)
JA8-2019 Compliant

E26 Medium Base Specifications
Lamping: E26 base, 60 W max,
G40 recommended
Bulb not included
Input voltage: 250 V AC max

Semigloss Black (CM-114) extended round canopy with SVT-3 Cable, Black (CM-039) and 1/16 Stainless Steel Cables (CM-053)
Canopy dimensions: 5" Ø, 2"
See website for more canopy information
Field adjustable drop length: 1'0" min - 8'0" max
Wood grain will vary
Specifications subject to change
Suitable for dry or damp locations

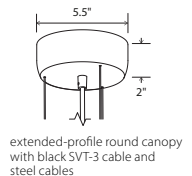

extended-profile round canopy with black SVT-3 cable and steel cables



brushed brass (CM-047)



distressed brass (CM-096)



brushed aluminum (CM-012)



brushed rose gold (CM-046)



black powder coat (CM-049)

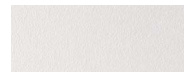

white powder coat (CM-060)



walnut (CM-001)



dark stained walnut (CM-002)



white washed oak (CM-095)

MATERIAL & FINISH OPTIONS

Aminus 21 part # 06-290-21-

Metal Shade

brushed brass (CM-047)
distressed brass (CM-096)
brushed aluminum (CM-012)
brushed rose gold (CM-046)
black powder coat (CM-049)
white powder coat (CM-060)

R
D
A
G
B
W

Wood Top

walnut (CM-001)
dark stained walnut (CM-002)
white washed oak (CM-095)

W
D
O

Lamping

2700 K LED
3500 K LED
medium base E26 socket

27
35
MB

Power Option (LED version only)

120-277 V AC input voltage
TRIAC and ELV dimming

P1

*Available in 3000K, 4000K and other color temperatures upon request



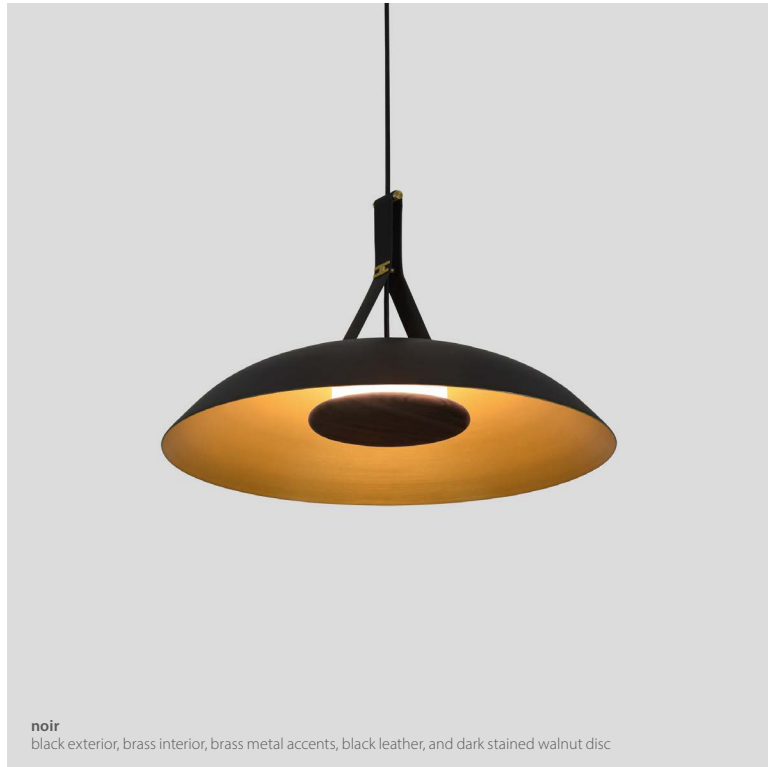

noir
black exterior, brass interior, brass metal accents, black leather, and dark stained walnut disc

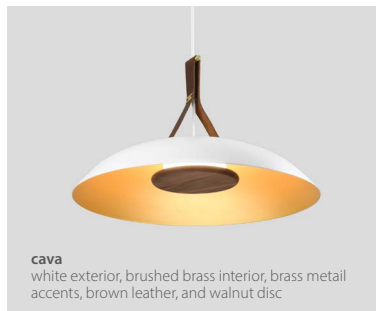

cava
white exterior, brushed brass interior, brass metal accents, brown leather, and walnut disc



deux
black exterior, white interior, black metal accents, brown leather, and walnut disc



blanc
white exterior and interior, brass metal accents, tan leather, and white washed oak disc



blanc,
leather and metal accents top details

The handcrafted Volo pendant is a celebration of natural materials. The solid hardwood, brass finish, leather, and aluminum showcase the purposeful design that went into each detail. The indirect LED light source emits light of beautiful quality.

Volo
pendant

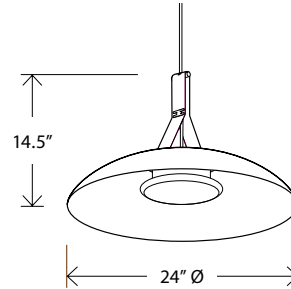

Dimensions: 24" Ø, 14.5"
Product weight: 7 lb
Light source: integrated LED
Light output: 2625 Lumens (source)
Output based on white shade interior
Alternate finishes will reduce lumen output
Light color: 2700 K, 3000 K, 3500 K, or 4000 K
Color accuracy: 90+ CRI
Power usage: 27 W
Dimmable (see power options below)
Wood grain will vary
Specifications subject to change



MATERIAL & FINISH OPTIONS

Volo pendant part # 06-300-

Finish Options	
noir	N
blanc	B
cava	C
deux	D
Lamping	
2700 K LED	27
3000 K LED	30
3500 K LED	35
4000 K LED	40
Power Option	
AC Input Voltage Range: 120-277 V	
120 V input: TRIAC, ELV & 0-10 V dimmable	P1
240 & 277 V input: only 0-10 V dimmable	



brushed brass (CM-120)



black powder coat (CM-049)



white powder coat (CM-060)

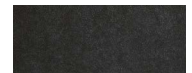

black leather (CM-127)

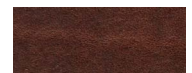

brown leather (CM-098)

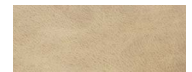

tan leather (CM-128)



walnut (CM-001)



dark stained walnut (CM-002)



white washed oak (CM-095)

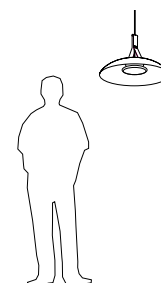

Casia 14
pendant

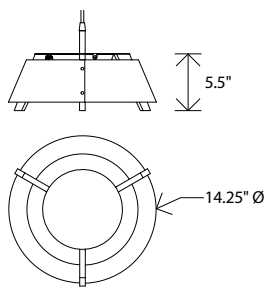
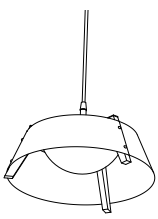

Dimensions: 14.25" Ø, 5.5"
Product weight: 3 lb
Light Color Options*:
2700 K - 831 Lumens (source)
3500 K - 873 Lumens (source)
Color accuracy: 90+ CRI
Power usage: 10 W

Dimmable (see power options below)
Low profile round canopy with SVT-3 Cable
Canopy dimensions: 5" Ø, 0.3"
See website for more canopy information
Field adjustable drop length:

0'6" min - 8'0" max

Gloss White (CM-054) shade option ships with Textured White Powder Coat Canopy and SVT-3 Cable, White (CM-040)
All other shade options ship with Textured Black Powder Coat (CM-049) and SVT-3 Cable, Black (CM-039)

Suitable for a sloped ceiling
Wood grain will vary

Specifications subject to change
JA8-2019 Compliant

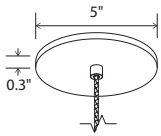

black low-profile round canopy with SVT-3 cable



matte black (CM-085) with matte white interior



distressed brass (CM-009)

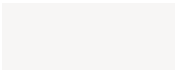

gloss white (CM-054)



walnut (CM-001)

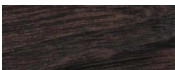

dark stained walnut (CM-002)



white washed oak (CM-095)

MATERIAL & FINISH OPTIONS

Casia 14 pendant part #: 06-280-14

Shade Material

matte black (CM-085) exterior with matte white interior
distressed brass (CM-009)
gloss white (CM-054)

Wood Body

walnut (CM-001)
dark stained walnut (CM-002)
white washed oak (CM-095)

Lamping

2700 K LED
3500 K LED
medium base E26 socket

Power Option

120-277 V AC input voltage
TRIAC and ELV dimming

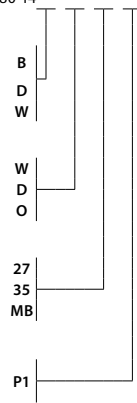

Includes: white glass diffuser (CM-109)

Available in a flush mount version

*Available in 3000K, 4000K and other color temperatures upon request



gloss white, white washed oak



matte black with matte white, dark stained walnut

The Casia pendant was a natural progression after releasing the Casia flush mount in early 2020. The wood arms, metal shade, and glass diffuser combine to create a minimalist form well suited for a modern environment or a traditional space. Each carefully selected material plays an integral role in the aesthetic design and performance.

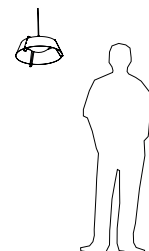



matte black with white matte, dark stained walnut

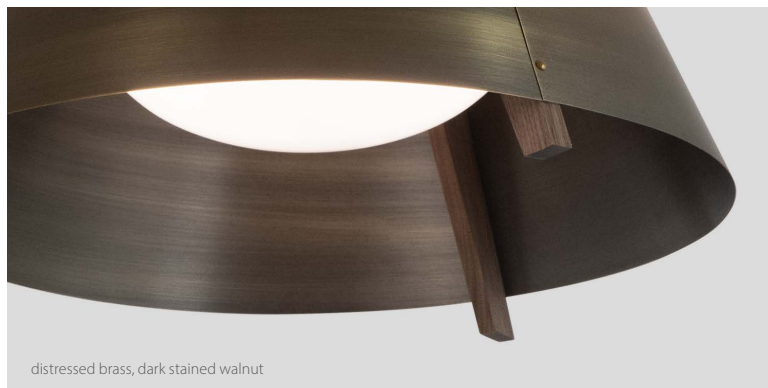

distressed brass, dark stained walnut

The Casia Pendant was a natural progression after releasing the Casia Flush Mount in early 2020. The wood arms, metal shade, and glass diffuser combine to create a minimalist form well suited for a modern environment or a traditional space. Each carefully selected material plays an integral role in the aesthetic design and performance.

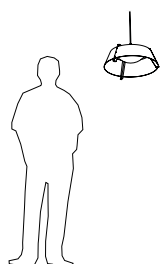

Casia 18 pendant

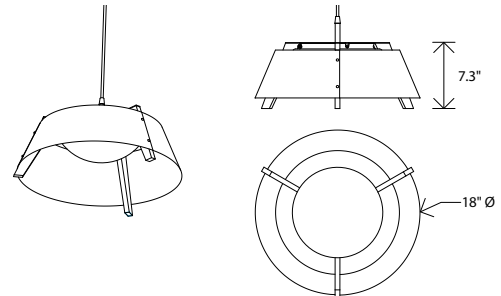

Dimensions: 18" Ø, 7.3"
 Product weight: 4 lb
 Light Color Options*:
 2700 K - 1310 Lumens (source)
 3500 K - 1378 Lumens (source)
 Color accuracy: 90+ CRI
 Power usage: 15 W
 Dimmable (see power options below)
 Low profile round canopy with SVT-3 Cable
 Canopy dimensions: 5" Ø, 0.3"
 See website for more canopy information
 Field adjustable drop length:
 0'6" min - 8'0" max
 Gloss White (CM-054) shade option ships with Textured White Powder Coat Canopy and SVT-3 Cable, White (CM-040)
 All other shade options ship with Textured Black Powder Coat (CM-049) and SVT-3 Cable, Black (CM-039)
 Suitable for a sloped ceiling
 Wood grain will vary
 Specifications subject to change
 JA8-2019 Compliant

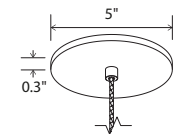

low-profile round canopy with SVT-3 cable



MATERIAL & FINISH OPTIONS

Casia 18 pendant part # 06-280-18-

Shade Material
 matte black (CM-085) exterior with matte white interior
 distressed brass (CM-009)
 gloss white (CM-054)

Wood Body
 walnut (CM-001)
 dark stained walnut (CM-002)
 white washed oak (CM-095)

Lamping
 2700 K LED
 3500 K LED

Power Option
 120-277 V AC input voltage
 TRIAC and ELV dimming

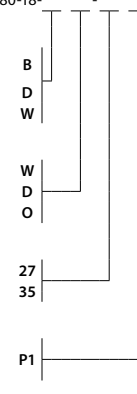

matte black (CM-085) with matte white interior

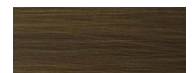

distressed brass (CM-009)

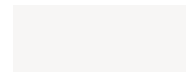

gloss white (CM-054)



walnut (CM-001)



dark stained walnut (CM-002)



white washed oak (CM-095)

Includes: white glass diffuser (CM-109)

Available in a flush mount version

*Available in 3000K, 4000K and other color temperatures upon request

Casia 22
pendant

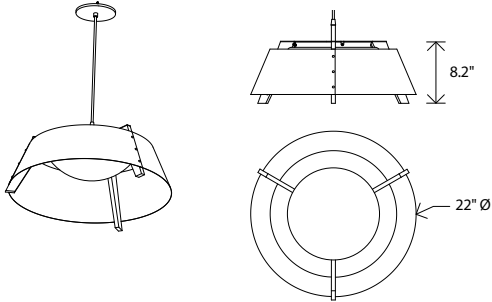

Dimensions: 21.5" Ø, 8.2"
 Product weight: 5 lb
 Light Color Options*:
 2700 K - 1981 Lumens (source)
 3500 K - 2083 Lumens (source)
 Color accuracy: 90+ CRI
 Power usage: 23 W
 Dimmable (see power options below)
 Low profile round canopy with SVT-3 Cable
 Canopy dimensions: 5" Ø, 0.3"
 See website for more canopy information
 Field adjustable drop length:
 0'6" min - 8'0" max
 Gloss White (CM-054) shade option ships with
 Textured White Powder Coat Canopy and SVT-3
 Cable, White (CM-040)
 All other shade options ship with Textured
 Black Powder Coat (CM-049) and
 SVT-3 Cable, Black (CM-039)
 Suitable for a sloped ceiling
 Wood grain will vary
 Specifications subject to change
 JA8-2019 Compliant

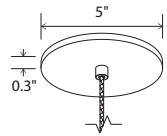

low-profile round canopy with SVT-3 cable



matte black (CM-085) with matte white interior



distressed brass (CM-009)

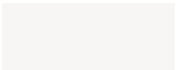

gloss white (CM-054)



walnut (CM-001)



dark stained walnut (CM-002)



white washed oak (CM-095)

MATERIAL & FINISH OPTIONS

Casia 22 pendant part #: 06-280-22

Shade Material	B	
matte black (CM-085) with matte white interior	D	
distressed brass (CM-009)	W	
gloss white (CM-054)		
Wood Body	W	
walnut (CM-001)	D	
dark stained walnut (CM-002)	O	
white washed oak (CM-095)		
Lamping	27	
2700 K LED	35	
3500 K LED	MB	
medium base E26 socket		
Power Option	P1	
120-277 V AC input voltage		
TRIAC and ELV dimming		

Includes: white glass diffuser (CM-109)

Available in a flush mount version

*Available in 3000K, 4000K and other color temperatures upon request



distressed brass, walnut



gloss white, white washed oak

The Casia Pendant was a natural progression after releasing the Casia Flush Mount in early 2020. The wood arms, metal shade, and glass diffuser combine to create a minimalist form well suited for a modern environment or a traditional space. Each carefully selected material plays an integral role in the aesthetic design and performance.

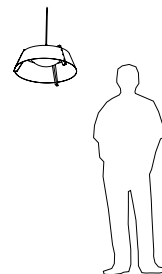

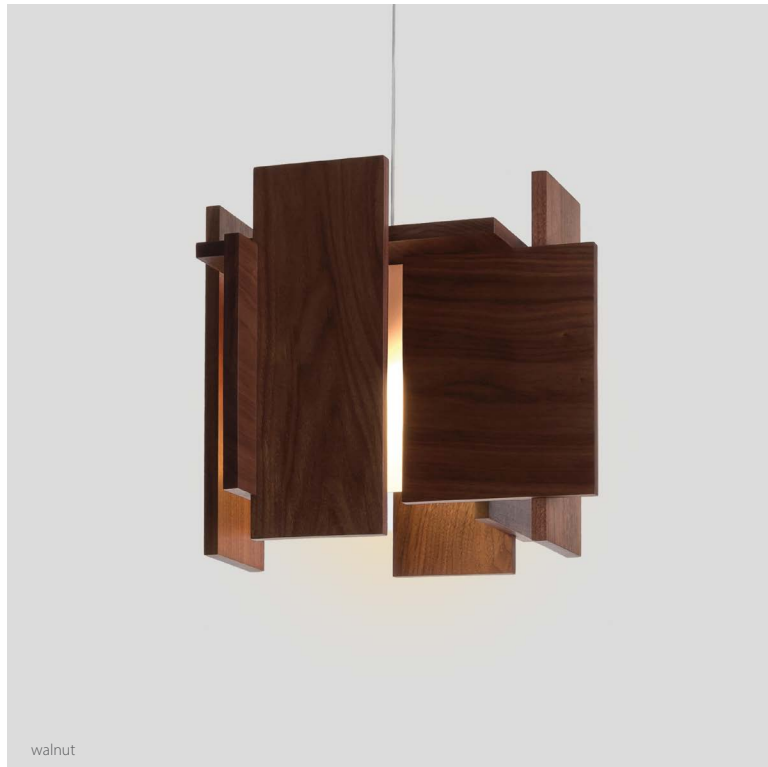

walnut



dark stained walnut



Abeo
pendant

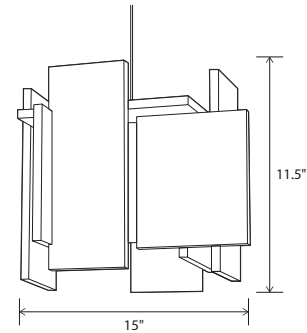

Dimensions: 15" Ø, 11.5"
 Materials: solid wood, polymer
 Product weight: 7 lb
 Light source: integrated LED
 Light output: 1250 Lumens (source)
 Light color*: 2700 K or 3500 K
 Color accuracy: 90+ CRI
 Power usage: 13 W
 Dimmable (see driver below)
 White (CM-060) extended-profile round canopy with white braided cord and steel cable included
 Canopy dimensions: 5.5"Ø, 2"
 Canopy required to house LED driver (3.3" x 1.6" x 1.0")
 See website for more canopy information
 6'-0" drop length, field adjustable
 Suitable for a sloped ceiling
 Wood grain will vary
 Specifications subject to change

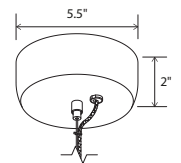

extended-profile round canopy



MATERIAL & FINISH OPTIONS

Abeo part # 06-190-

Wood Body	
walnut (CM-001)	W
dark stained walnut (CM-002)	D
Lamping	
2700 K LED	27
3500 K LED	35
Driver	
AC Input Voltage Range: 120-277 V	
120 V input:	
TRIAC, ELV & 0-10 V dimmable	P1
240 & 277 V input:	
only 0-10 V dimmable	



walnut (CM-001)



dark stained walnut (CM-002)

Includes: frosted polymer (CM-024)

*Available in 3000K, 4000K and other color temperatures upon request

I wanted to create a simple geometric sculpture that lets the light inside just sneak out around the floating walnut planes: letting the natural wood fall in and out of the light. It is this play with contrast and light and shadow that makes the Abeo such a dynamic piece.

Nick Sheridan,
Designer

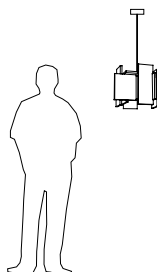



Spero pendant, black / black leather



brass / brown leather



white / tan leather



black / black leather



distressed brass / black leather



details

The Spero Pendant illustrates a minimalist mindset without sacrificing design details that define the fixture. Pronounced metal accents join the leather strap to the shade, adding a balanced contrast between the different elements. The bottom aperture allows the delivery of ample light while shielding the rest of the space from glare.

Spero
pendant

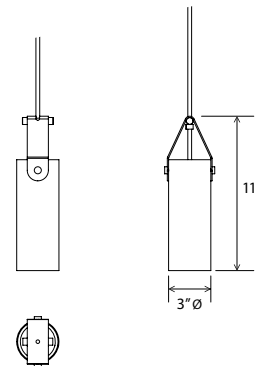

Dimensions: 3" Ø, 11"
 Product weight: 2 lb
 Field adjustable drop length:
 0'6" min - 8'0" max
 Canopy color matches cord
 Lamping: 1x E26 base, PAR20 lamp, 20 W max
 Specifications subject to change



MATERIAL & FINISH OPTIONS

Spero pendant part # 06-310-

Standard Combinations

black / black leather	B
brass / brown leather	R
distressed brass / black leather	D
white / tan leather	W

Lamping

PAR20 LED bulb included - 2700 K, 90CRI, 40 degree flood	27
no bulb included	00



brass



black

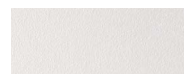

white



distressed brass

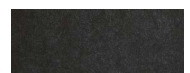

black leather

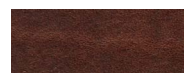

brown leather

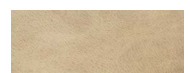

tan leather

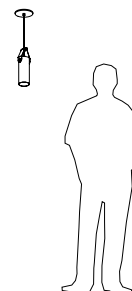

Cano
pendant

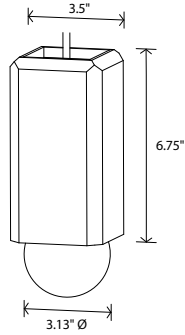

Dimensions: 3.5" x 3.5", 6.75"
 Materials: solid wood
 Product weight: 2 lb
 Light source: medium base E26 socket
 Lamping: E26 base, type G25 lamp, 20 W max
 Input voltage: 250 V AC max
 Textured Black Powdercoat (CM-049) low profile round canopy with Grey Cloth Covered Cord (CM-106)
 Canopy dimensions: 5" Ø, 0.3"
 See website for more canopy information
 Field adjustable drop length: 0'6" min - 6'0" max
 Suitable for a sloped ceiling
 Wood grain will vary
 Specifications subject to change
 Optional dimmable LED G25 bulb
 Light output: 500 Lumens (source)
 Color accuracy: 90+ CRI
 Power usage: 5.5 W



white washed oak

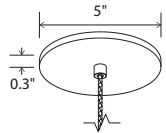

low profile round canopy with braided cord



walnut

dark stained walnut

MATERIAL & FINISH OPTIONS

Cano part #: 06-251- - MB

Wood Shade		
walnut (CM-001)	W	
dark stained walnut (CM-002)	D	
white washed oak (CM-095)	O	
Lamping		
2700 K G25 LED bulb included	27	
no bulb included	00	



walnut (CM-001)



dark stained walnut (CM-002)



white washed oak (CM-095)

Designing with LEDs often lends itself to hiding, or using a low profile light source. The Cano pendant does the opposite; the light bulb is an integral part of the design. The solid hardwood faceted body is enhanced when paired with a spherical glowing bulb.

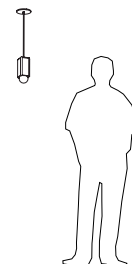



Built of one inch thick solid hardwood, the Bimar showcases the beauty of natural woodgrain. Eight faceted sides compose a design that works well in a modern or transitional space. The combination of natural wood and a glowing sphere bulb warms up any environment.

Bimar
pendant

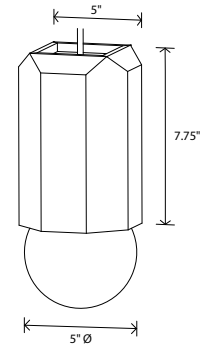

Dimensions: 5" x 5", 7.75"
 Materials: solid wood
 Product weight: 3 lb
 Light source: medium base E26 socket
 Lamping: E26 base, type G40 lamp, 20 W max
 Input voltage: 250 V AC max
 Textured Black Powder Coat (CM-049)
 low profile round canopy with Grey Cloth Covered Cord (CM-106)
 Canopy dimensions: 5" Ø, 0.3"
 See website for more canopy information
 Field adjustable drop length:
 0'6" min - 6'0" max
 Suitable for a sloped ceiling
 Wood grain will vary
 Specifications subject to change
 Optional dimmable LED G40 bulb
 Light output: 1000 Lumens (source)
 Color accuracy: 90+ CRI
 Power usage: 11 W

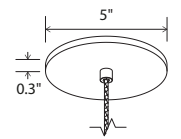

low profile round canopy with braided cord

MATERIAL & FINISH OPTIONS

Bimar part # 06-250-		-	MB
Wood Shade			
walnut (CM-001)	W		
dark stained walnut (CM-002)	D		
white washed oak (CM-095)	O		
Bulb Options			
2700 K G40 LED Bulb included	27		
no bulb included	00		



walnut (CM-001)



dark stained walnut (CM-002)



white washed oak (CM-095)

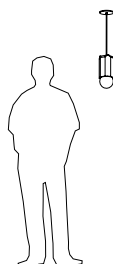

Muto
pendant

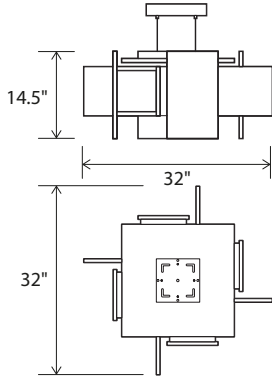

Dimensions: 32" x 32", 14.5"
 Materials: solid wood, polymer
 Product weight: 17 lb
 Light source: integrated LED
 Light output - total: 2626 Lumens (source)
 Light output - ambient: 1376 Lumens (source)
 Light output - downlight: 1250 Lumens (source)
 Light color*: 2700 K or 3500 K
 Color accuracy: 90+ CRI
 Power usage: 25 W
 Dimmable (see driver below)
 Brushed aluminum (CM-006) 8" square canopy with black mesh cables included
 Canopy dimensions: 8" x 8", 1.5"
 See instructions for additional canopy details at cernogroup.com
 6'-0" drop length, field adjustable
 Suitable for a sloped ceiling
 Wood grain will vary
 Specifications subject to change

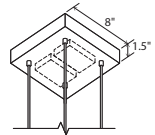

8" square canopy with black mesh cables



walnut (CM-001)



dark stained walnut (CM-002)

MATERIAL & FINISH OPTIONS

Muto part #: 06-140-

Wood Body		
walnut (CM-001)	W	
dark stained walnut (CM-002)	D	
Lamping		
2700 K LED	27	
3500 K LED	35	
Driver		
AC Input Voltage Range: 120-277 V		
120 V input:		
TRIAC, ELV & 0-10 V dimmable	P1	
240 & 277 V input: only 0-10 V dimmable		

Includes: frosted polymer (CM-024)

*Available in 3000K, 4000K and other color temperatures upon request.



walnut



walnut, under view



dark stained walnut

The way the walnut planes in the Muto both block and bounce light makes for a very dynamic composition of light and shadow, from any vantage point. While the pinwheel form with its repeating elements is symmetric, it appears very sculptural from any one view. The modern floating ideal is realized in the Muto. By holding each walnut element away from its neighbor, so each plane floats, the whole fixture feels weightless as if it were floating itself.

Nick Sheridan,
Designer

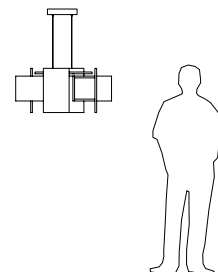

Astrum 11 pendant



distressed brass



gloss white



matte black

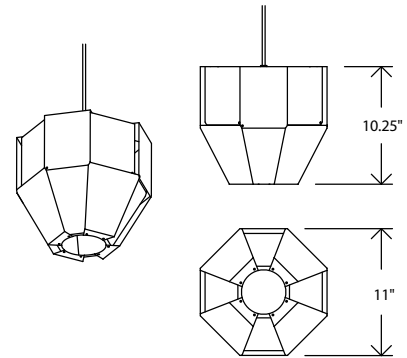

Dimensions: 11" x 11", 10.25"
Product weight: 2 lb
Suitable for a sloped ceiling

Integrated LED Specifications

Light output: 1690 Lumens (source)
Light color: 2700 K, 3000 K, 3500 K or 4000 K
Color accuracy: 90+ CRI
Power usage: 19.5 W
Dimmable (see driver below)
Driver must be housed in J-box
Driver dimensions: 3.3" x 1.6" x 1", included

E26 Medium Base Specifications

Lamping: E26 base, type A lamp, 60 W max
Input voltage: 250 V AC max
Bulb not included

Textured Black Powder Coat (CM-049) low profile round canopy with SVT-3 Cable, Black (CM-039)
Canopy dimensions: 5" Ø, 0.3"
See website for more canopy information
Field adjustable drop length: 0'6" min - 8'0" max
Specifications subject to change

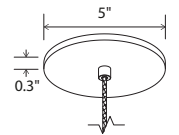

low profile round canopy with braided cord



MATERIAL & FINISH OPTIONS

Astrum 11 part # 06-270-11

Shade Material
matte black (CM-085) with matte white interior
distressed brass (CM-096)
gloss white (CM-054)

Lamping
2700 K LED
3000 K LED
3500 K LED
4000 K LED
medium base E26 socket

Driver (LED version only)
AC Input Voltage Range: 120-277 V
120 V input: TRIAC, ELV & 0-10 V dimmable
240 & 277 V input: only 0-10 V dimmable

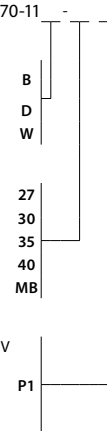

matte black (CM-085)



distressed brass (CM-096)

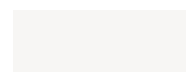

gloss white (CM-054)

Inspiration for the Astrum dates back to the first light fixture the three of us ever made after starting Cerno. The varying depths of the flat panels strategically obstruct a direct view of the light source. Light reflects off the inside of the outer panels and bounces off the inner panels producing a halo washing effect. The oculus at the bottom functions to emit a useful amount of downlighting. This design manages to pay homage to past modern designs while also feeling a bit futuristic.

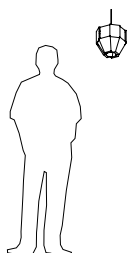



Astrum pendant, white gloss



white gloss



distressed brass



matte black

Inspiration for the Astrum dates back to the first light fixture the three of us ever made after starting Cerno. The varying depths of the flat panels strategically obstruct a direct view of the light source. Light reflects off the inside of the outer panels and bounces off the inner panels producing a halo washing effect. The oculus at the bottom functions to emit a useful amount of downlighting. This design manages to pay homage to past modern designs while also feeling a bit futuristic.

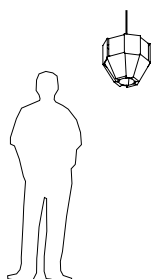

Astrum 17 pendant

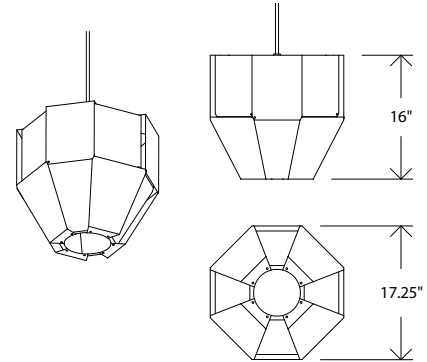

Dimensions 17.25" x 17.25", 16"
Product weight: 4 lb
Suitable for a sloped ceiling

Integrated LED Specifications

Light output: 1690 Lumens (source)
Light color: 2700 K, 3000 K, 3500 K or 4000 K
Color accuracy: 90+ CRI
Power usage: 19.5 W
Dimmable (see driver below)
Driver must be housed in J-box
Driver dimensions: 3.3" x 1.6" x 1", included

E26 Medium Base Specifications

Lamping: 2x E26 base, type A lamp,
60 W max each
Input voltage: 250 V AC max
Bulbs not included

Textured Black Powder Coat (CM-049) low
profile round canopy with SVT-3 Cable,
Black (CM-039)
Canopy dimensions: 5" Ø, 0.3"
See website for more canopy information
Field adjustable drop length:
0'6" min - 8'0" max
Specifications subject to change

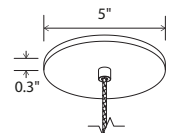

black low profile round canopy
with braided cord



MATERIAL & FINISH OPTIONS

Astrum 17 part # 06-270-17

Shade Material
matte black (CM-085) with matte
white interior
distressed brass (CM-096)
gloss white (CM-054)

Lamping

2700 K LED
3000 K LED
3500 K LED
4000 K LED
medium base E26 socket

Driver (LED version only)

AC Input Voltage Range: 120-277 V
120 V input:
TRIAC, ELV & 0-10 V dimmable
240 & 277 V input:
only 0-10 V dimmable

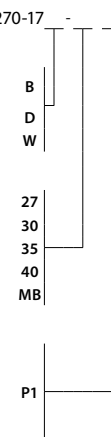

matte black (CM-085)



distressed brass (CM-096)

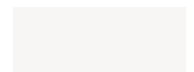

gloss white (CM-054)



distressed brass, walnut

Imber 17 / 24
pendant

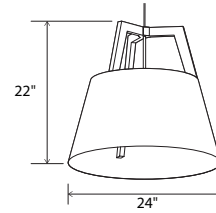
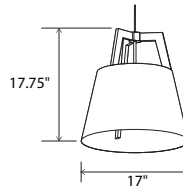

Imber 17 dimensions: 17" Ø, 17.75"
 Imber 24 dimensions: 24" Ø, 22"
 Materials: solid wood, metal
 Imber 17 weight: 7 lb
 Imber 24 weight: 12 lb
 Wood grain will vary
 Specifications subject to change



DIFFUSER
 Frosted white diffuser (CM-024)
 Diffuser is recommended when fixture location
 may allow for direct glare
 Integrated LED option always comes with a diffuser

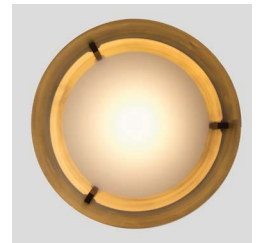

MATERIAL & FINISH OPTIONS

Imber part #: 06-210-

<i>Fixture Size</i>		
17" Ø	17	
24" Ø	24	
<i>Standard Combinations (Shade & Frame)</i>		
distressed brass, walnut	DW	
distressed brass, dark stained walnut	DD	
brushed brass, walnut	RW	
brushed rose gold, dark stained walnut	GD	
matte black with matte white interior, dark stained walnut	BD	
matte black with matte white interior, white washed oak	BO	
matte black with matte white interior, walnut	BW	
gloss white, white washed oak	WO	
<i>Suspension Type</i>		
corded	C	
rigid	R	
<i>Lamping</i>		
integrated LED with diffuser - 2700 K	L27	
integrated LED with diffuser - 3500 K	L35	
medium base socket without diffuser	S	
medium base socket with diffuser	D	

SUSPENSION TYPE

Corded
 8' length of SVT wire is used. Wire is field
 adjustable and suitable for a sloped ceiling
Rigid
 Stem comes 6' long and is field cuttable
 to length (0.38" Ø)

SUSPENSION & HARDWARE FINISH

Standard Combinations
 Come with either black or satin nickel & white
 suspension, canopy, and sockets:
 Black: DW, DD, RW, GD, BD, BO, BW
 Satin Nickel & White: WO
Corded Versions
 White cord: satin nickel hardware
 Black cord: black hardware
 24" Imber corded uses a 1/16" Ø steel
 cable for suspension

CANOPIES

See website for more canopy information
 See Suspension & Hardware for canopy finishes
 Canopy types:
Imber 17 with LED lamping
 Extended-profile round canopy, braided
 cord included, required to house the
 LED driver (3.25" x 2.25" x 1.25")
 Canopy dimensions: 5.5 Ø, 2" deep
Imber 17 with Medium base socket
 Low-profile round canopy, SVT included
Imber 24 with LED lamping
 Extended-profile round canopy, braided cord
 with steel cable included, required to house
 the LED driver (3.25" x 2.25" x 1.25")
 Canopy dimensions: 5.5" Ø, 2" deep
Imber 24 with Medium base socket
 Low-profile round canopy, SPT w/steel cable included

LAMPING

Integrated LED Specifications

Light output: 1250 Lumens (source)
 Light color* : 2700 K or 3500 K
 Color accuracy: 90+ CRI
 Power usage: 13 W
 Input voltage: 120-277 V AC
 Dimmable: 0-10 V dimming at 120-277 V AC
 TRIAC and ELV dimming at 120 V AC only

Medium Base E26 Specifications

Imber 17 lamping: 1x E26 base,
 type A lamp, 75 W max
 Imber 24 lamping: 3x E26 base,
 type A lamp, 75 W max each
 Bulbs not included
 Input voltage: 250 V AC max

*Available in 3000K, 4000K and other
 color temperatures upon request

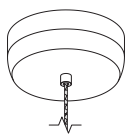

Imber 17 with LED lamping
 Extended-profile round canopy,
 with braided cord

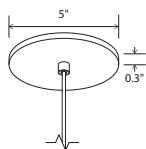

Imber 17 w/medium base socket
 Low-profile round canopy, with
 SVT cable

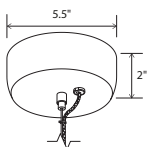

Imber 24 with LED lamping
 Extended-profile round canopy,
 braided cord with steel cable

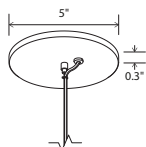

Imber 24 w/medium base socket
 Low-profile round canopy,
 SPT with steel cable



distressed brass, walnut

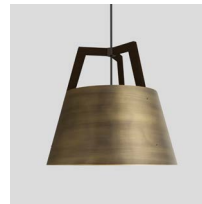

DD: distressed brass (CM-009), dark stained walnut (CM-002)



GD: brushed rose gold (CM-046), dark stained walnut (CM-002)



RW: brushed brass (CM-047), walnut (CM-001)

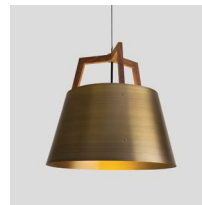

DW: distressed brass (CM-009), dark stained walnut (CM-001)



WO: gloss white (CM-054), white washed oak (CM-095)



BW: matte black with matte white interior (CM-085), walnut (CM-001)

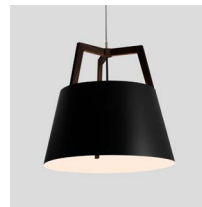

BD: matte black with matte white interior (CM-085), dark stained walnut (CM-002)



BO: matte black with matte white interior (CM-085), white washed oak (CM-095)

The Ignis and Imber were inspired by the same design principles that make Cerno and ICRAVE well suited to collaborate. Honesty, simplicity, elemental, timeless and quality are words that sit at the core of both companies' design ethos and we believe these light fixtures embrace these qualities well. Each fixture was reduced to its essential parts – frame and shade – highlighting the interplay of the components, and accentuating the clean lines of the form.

ICRAVE / Cerno

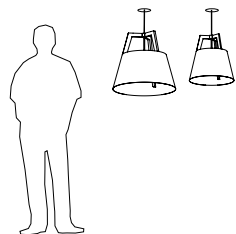



matte black with matte white interior, white washed oak

Ignis 17 / 24
pendant

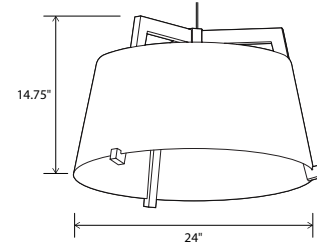
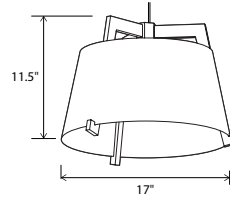

Ignis 17 dimensions: 17" Ø, 11.5"
Ignis 24 dimensions: 24" Ø, 14.75"
Materials: solid wood, metal
Ignis 17 weight: 7 lb
Ignis 24 weight: 11 lb
Wood grain will vary
Specifications subject to change



DIFFUSER
Frosted white diffuser (CM-024)
Diffuser is recommended when fixture location
may allow for direct glare
Integrated LED option always comes with a diffuser



MATERIAL & FINISH OPTIONS

Ignis part #: 06-220-

Fixture Size		
17" Ø	17	
24" Ø	24	
Standard Combinations (Shade & Frame)		
distressed brass, walnut	DW	
distressed brass, dark stained walnut	DD	
brushed brass, walnut	RW	
brushed rose gold, dark stained walnut	GD	
matte black with matte white interior, dark stained walnut	BD	
matte black with matte white interior, white washed oak	BO	
matte black with matte white interior, walnut	BW	
gloss white, white washed oak	WO	
Suspension Type		
corded	C	
rigid	R	
Lamping		
integrated LED with diffuser - 2700 K	L27	
integrated LED with diffuser - 3500 K	L35	
medium base socket without diffuser	S	
medium base socket with diffuser	D	

SUSPENSION TYPE
Corded: 8' length of SVT wire is used. Wire is field adjustable and suitable for a sloped ceiling
Rigid: Stem comes 6' long and is field cuttable to length (0.38" Ø)

SUSPENSION & HARDWARE FINISH
Standard Combinations
Come with either black or satin nickel & white suspension, canopy, and sockets:
Black: DW, DD, RW, GD, BD, BO, BW
Satin Nickel & White: WO

Corded Versions
White cord: satin nickel hardware
Black cord: black hardware
24" Ignis corded uses a 1/16" Ø with steel cable for suspension

CANOPIES

See website for more canopy information
See Suspension & Hardware for canopy finishes
Canopy types:

Ignis 17 with LED lamping

Extended-profile round canopy, braided cord included, required to house the LED driver (3.25" x 2.25" x 1.25")
Canopy dimensions: 5.5" Ø, 2" deep

Ignis 17 with Medium base socket

Low-profile round canopy, SVT included

Ignis 24 with LED lamping

Extended-profile round canopy, braided cord with steel cable included, required to house the LED driver (3.25" x 2.25" x 1.25")
Canopy dimensions: 5.5" Ø, 2" deep

Ignis 24 with Medium base socket

Low-profile round canopy, SPT w/steel cable included

LAMPING

Integrated LED Specifications

Light output: 1250 Lumens (source)
Light color*: 2700 K or 3500 K
Color accuracy: 90+ CRI
Power usage: 13 W
Input voltage: 120-277 V AC
Dimmable: 0-10 V dimming at 120-277 V AC
TRIAC and ELV dimming at 120 V AC only

Medium Base E26 Specifications

Ignis 17 lamping:
1x E26 base, type A lamp, 75 W max
Ignis 24 lamping:
3x E26 base, type A lamp, 75 W max each
Bulbs not included
Input voltage: 250 V AC max

*Available in 3000K, 4000K and other color temperatures upon request

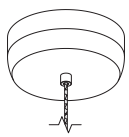

Ignis 17 with LED lamping
Extended-profile round canopy, braided cord

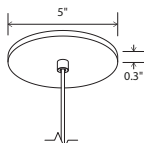

Ignis 17 w/medium base socket
Low-profile round canopy, with SVT cable

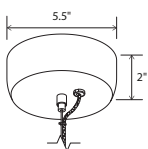

Ignis 24 with LED lamping
Extended-profile round canopy, braided cord with steel cable

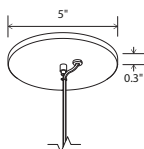

Ignis 24 w/medium base socket
Low-profile round canopy, SPT with steel cable



distressed brass, walnut



DD: distressed brass (CM-009), dark stained walnut (CM-002)



GD: brushed rose gold (CM-046), dark stained walnut (CM-002)



RW: brushed brass (CM-047), walnut (CM-001)



DW: distressed brass (CM-009), walnut (CM-001)



WO: gloss white (CM-054), white washed oak (CM-095)



BW: matte black with matte white interior (CM-085), walnut (CM-001)



BD: matte black with matte white interior (CM-085), dark stained walnut (CM-002)



BO: matte black with matte white interior (CM-085), white washed oak (CM-095)

The Ignis and Imber were inspired by the same design principles that make Cerno and ICRAVE well suited to collaborate. Honesty, simplicity, elemental, timeless and quality are words that sit at the core of both companies' design ethos and we believe these light fixtures embrace these qualities well. Each fixture was reduced to its essential parts – frame and shade – highlighting the interplay of the components, and accentuating the clean lines of the form.

ICRAVE / Cerno

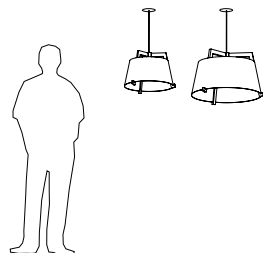



Custom Cymbals pendants



Ico 20
pendant

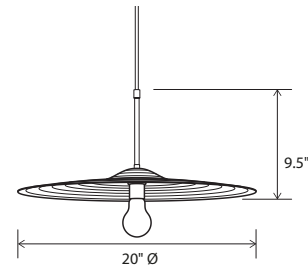

Dimensions: 20" Ø, 9.5"
 Materials: solid brass
 Product weight: 6 lb
 Light source: medium base E26 socket
 Lamping: 1x E26 base, 60 W max
 Bulbs not included
 Input voltage: 250 V AC max
 Textured Black Powder Coat (CM-049) low
 profile round canopy with Black Cloth
 Covered Cord (CM-090)
 Canopy dimensions: 5" Ø, 0.3"
 See website for more canopy information
 Field adjustable drop length:
 0'9" min - 8'0" max
 Suitable for a sloped ceiling
 Specifications subject to changes

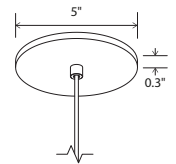

low-profile round canopy with
black cloth covered cord



MATERIAL & FINISH OPTIONS

	Ico part # 06-240-20	R - C
Size	20"	
Shade Finish	R	
spon solid brass (CM-091)		
Suspension	C	
corded (CM-090)		

Includes: brushed brass (CM-008)

After working with drum cymbals on a few custom projects, we grew to appreciate the design and engineering that goes into these beautiful objects. Cymbals have a simple form, rich texture, and a beautiful brass finish. Modernism is often about utilizing what already exists and repurposing things, which is what we did with this fixture. The Ico looks excellent when paired with a simple light bulb.

Nick Sheridan,
Designer

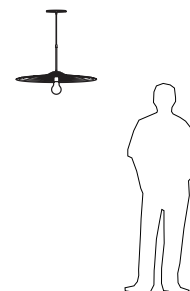



calx 10: brushed aluminum, dark stained walnut

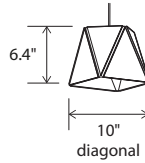

Dimensions: 6.75" x 6.75", 6.4"
 Materials: wood, metal, polymer
 Product weight: 2 lb
 Light source: integrated LED
 Light output: 345 Lumens (source)
 Light color*: 2700 K or 3500 K
 Color accuracy: 90+ CRI
 Power usage: 3.2 W
 Dimmable (see driver below)
 Driver location: must be housed in J-box
 Driver dimensions: 2" x 1.3" x 1", included
 White (CM-060) low-profile round canopy with white braided cord included
 Canopy dimensions: 5"Ø, 0.3"
 See website for more canopy information
 6'-0" drop length, field adjustable
 Suitable for a sloped ceiling
 Wood grain will vary
 Specifications subject to change



MATERIAL & FINISH OPTIONS

Calx 10 part #: 06-200-10

<i>Metal Finish</i>			
brushed aluminum (CM-012)	A		
brushed rose gold (CM-046)	G		
brushed brass (CM-047)	R		
<i>Wood Finish</i>			
walnut (CM-055)	W		
dark stained walnut (CM-056)	D		
white washed oak (CM-095)	O		
<i>Lamping</i>			
2700 K LED	27		
3500 K LED	35		
<i>Driver</i>			
120 V AC input voltage TRIAC, ELV, or 0-10V dimmable	P1		

Other sizes and Calx scone also available
 *Available in 3000K, 4000K and other color temperatures upon request

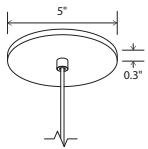

Calx 10:
 low-profile square canopy with white braided cord

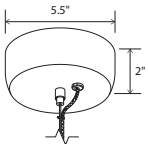

Calx 19 Integrated LED:
 extended-profile round canopy with white braided cord and steel cable

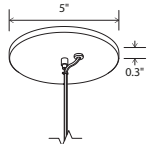

Calx 19 Medium Base:
 low-profile round canopy with white SPT cord and steel cable

Calx 10 / 19
 pendant

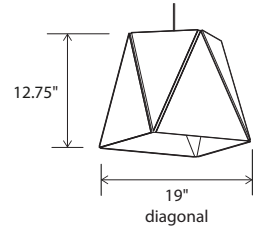

Dimensions: 13" x 13", 12.75"
 Materials: wood, metal, polymer
 Product weight: 7 lb
Integrated LED Specifications
 Light output: 1250 Lumens (source)
 Light color*: 2700 K or 3500 K
 Color accuracy: 90+ CRI
 Power usage: 13 W
 Dimmable (see driver below)
 White (CM-060) extended-profile round canopy with white braided cord and steel cable included
 Canopy dimensions: 5"Ø, 2"
 Canopy required to house LED driver (3.3" x 1.6" x 1.0")
 See website for more canopy information
 6'-0" drop length, field adjustable
Medium Base Specifications
 Lamping: 1x E26 base, type A lamp, 60 W max
 Bulb not included
 Input voltage: 250 V AC max
 White (CM-060) low-profile round canopy w/white SPT cord and steel cable included
 Canopy dimensions: 5"Ø, 0.3"
 72" drop length, field adjustable
 Suitable for a sloped ceiling
 Wood grain will vary
 Specifications subject to change



MATERIAL & FINISH OPTIONS

Calx 19 part #: 06-200-19

<i>Metal Finish</i>			
brushed aluminum (CM-012)	A		
brushed rose gold (CM-046)	G		
brushed brass (CM-047)	R		
<i>Wood Finish</i>			
walnut (CM-055)	W		
dark stained walnut (CM-056)	D		
white washed oak (CM-095)	O		
<i>Lamping</i>			
2700 K LED	27		
3500 K LED	35		
medium base E26 socket	MB		
<i>Driver</i>			
AC Input Voltage Range: 120-277 V 120 V input: TRIAC, ELV & 0-10 V dimmable 240 & 277 V input: only 0-10 V dimmable	P1		

Other sizes and Calx scone also available
 *Available in 3000K, 4000K and other color temperatures upon request



calx 19: white washed oak, brushed aluminum

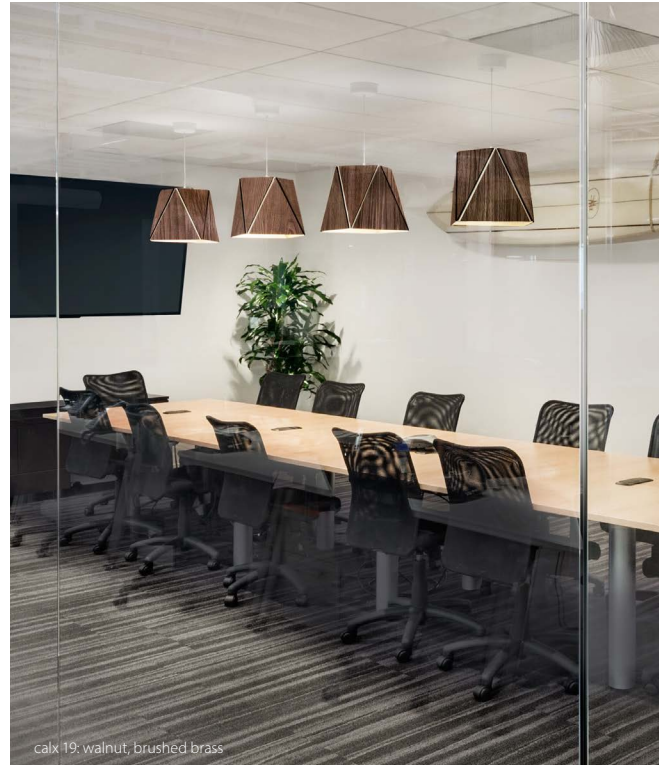

calx 19: walnut, brushed brass



calx 10: dark stained walnut, on Motus Swing Arm Bracket

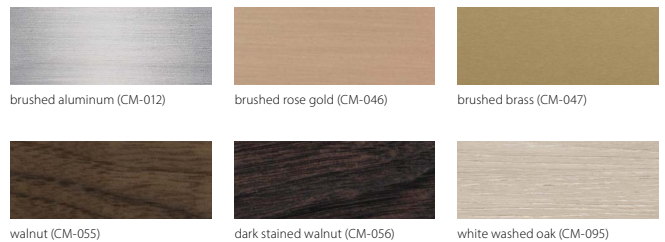

The Calx is an example of modern design where the methods and the materials themselves are integral to its very conception, aligning form and function, which creates a synergy that is evident. The fixture ultimately forms a square aperture but enjoys a beautifully simple faceted structure.

Nick Sheridan,
Designer

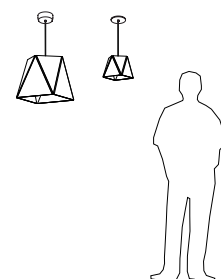





brushed aluminum, walnut



brushed aluminum, walnut

The Calx is an example of modern design where the methods and the materials themselves are integral to its very conception, aligning form and function, which creates a synergy that is evident. The fixture ultimately forms a square aperture but enjoys a beautifully simple faceted structure.

Nick Sheridan,
Designer

Calx 36
pendant

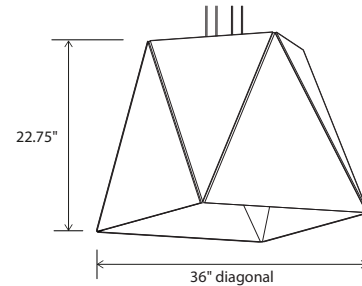

Dimensions: 25" x 25", 22.75"
 Materials: wood, metal, polymer
 Product weight: 18 lb
 Light source: 4x GU-24 base socket
 Lamping: 4x GU-24 base, 18 W max each
 Bulbs not included
 Input voltage: 300 V AC max
 White (CM-060) 8" round canopy included
 Canopy dimensions: 8"Ø, 1.25"
 See website for more canopy information
 8'-0" drop length, field adjustable
 Suitable for a sloped ceiling
 Wood grain will vary
 Specifications subject to change

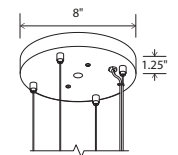

round 8" white multipoint canopy with clear SPT cord and steel cable

MATERIAL & FINISH OPTIONS

Calx 36 part # 06-200-36

Metal Finish

- brushed aluminum (CM-012) A
- brushed rose gold (CM-046) G
- brushed brass (CM-047) R

Wood Finish

- walnut (CM-055) W
- dark stained walnut (CM-056) D
- white washed oak (CM-095) O

Includes: frosted polymer diffuser (CM-057)

Other sizes and Calx sconce also available



brushed aluminum (CM-012)



brushed rose gold (CM-046)



brushed brass (CM-047)



walnut (CM-055)



dark stained walnut (CM-056)



white washed oak (CM-095)

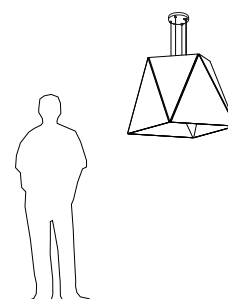

Veris 12
pendant

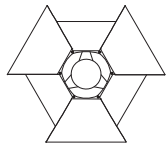
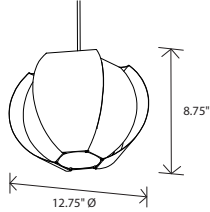
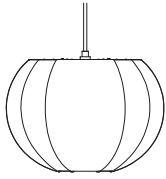

Dimensions: 12.75" Ø, 8.75"
Product weight: 2 lb
Suitable for a sloped ceiling

Integrated LED Specifications

Light output: 1690 Lumens (source)
Light color: 2700 K, 3000 K, 3500 K or 4000 K
Color accuracy: 90+ CRI
Power usage: 19.5 W

Dimmable (see driver below)
Driver must be housed in J-box
Driver dimensions: 3.3" x 1.6" x 1", included

E26 Medium Base Specifications

Lamping: E26 base, type A lamp, 60 W max
Input voltage: 250 V AC max
Bulb not included

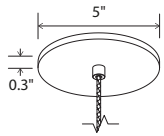

low-profile round canopy with black SVT-3 cable

Textured Black powder coat (CM-049)
low profile round canopy with SVT-3 Cable,
Black (CM-039)
Canopy dimensions: 5" Ø, 0.3"
See website for more canopy information
Field adjustable drop length: 0'6" min - 8'0" max
Specifications subject to change



MATERIAL & FINISH OPTIONS

Veris 12 part #: 06-260-12 -

Shade Material

- matte black (CM-085) with matte white interior
- brushed aluminum (CM-012)
- brushed rose gold (CM-046)
- brushed brass (CM-047)
- distressed brass (CM-096)
- gloss white (CM-054)

Lamping

- 2700 K LED
- 3000 K LED
- 3500 K LED
- 4000 K LED
- medium base E26 socket

Driver (LED version only)

- AC Input Voltage Range: 120-277 V
- 120 V input: TRIAC, ELV & 0-10 V dimmable
- 240 & 277 V input: only 0-10 V dimmable

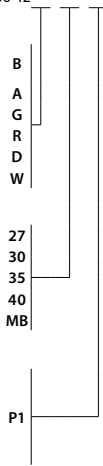

matte black w/matte white interior



gloss white, closeup

Veris was a concept we started exploring ten years ago. Two offset layers of petals simultaneously shield the light source while allowing reflected light to wash the inside petals, creating a dramatic ambient luminaire. The form materializes through a series of processes that utilize cutting edge CNC laser technology but still rely on skilled hand-rolling and bending of the aluminum petals.

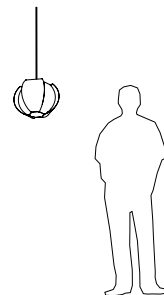

matte black (CM-085) with matte white interior



brushed aluminum (CM-012)



brushed rose gold (CM-046)



brushed brass (CM-047)



distressed brass (CM-096)

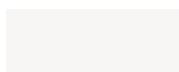

gloss white (CM-054)



matte black w/matte white interior



gloss white



Veris was a concept we started exploring ten years ago. Two offset layers of petals simultaneously shield the light source while allowing reflected light to wash the inside petals, creating a dramatic ambient luminaire. The form materializes through a series of processes that utilize cutting edge CNC laser technology but still rely on skilled hand-rolling and bending of the aluminum petals.

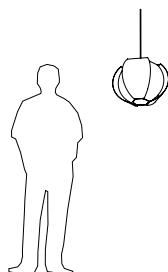

Veris 22

pendant

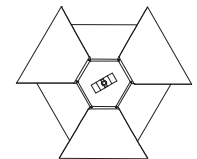
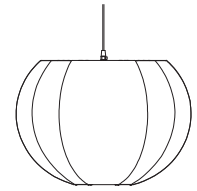
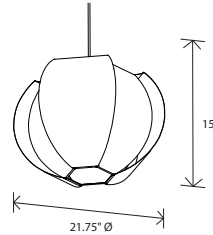

Dimensions: 21.75" Ø, 15"
 Product weight: 4 lb
 Suitable for a sloped ceiling

Integrated LED Specifications

Light output: 1690 Lumens (source)
 Light color: 2700 K, 3000 K, 3500 K or 4000 K
 Color accuracy: 90+ CRI
 Power usage: 19.5 W
 Dimmable (see driver below)
 Driver must be housed in J-box
 Driver dimensions: 3.3" x 1.6" x 1", included

E26 Medium Base Specifications

Lamping: 2x E26 base, type A lamp,
 60 W max each
 Input voltage: 250 V AC max
 Bulbs not included

Textured Black powder coat (CM-049) low profile round canopy with black SVT-3 Cable, Black (CM-039)
 Canopy dimensions: 5" Ø, 0.3"
 See website for more canopy information
 Field adjustable drop length: 0'6" min - 8'0" max
 Specifications subject to change

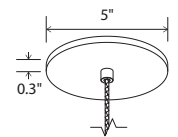

low-profile round canopy with black SVT-3 cable



MATERIAL & FINISH OPTIONS

Veris 22 part # 06-260-22

Shade Material

- matte black (CM-085) with matte white interior
- brushed aluminum (CM-012)
- brushed rose gold (CM-046)
- brushed brass (CM-047)
- distressed brass (CM-096)
- gloss white (CM-054)

Lamping

- 2700 K LED
- 3000 K LED
- 3500 K LED
- 4000 K LED
- medium base E26 socket

Driver (LED version only)

- AC Input Voltage Range: 120-277 V
- 120 V input:
- TRIAC, ELV & 0-10 V dimmable
- 240 & 277 V input:
- only 0-10 V dimmable

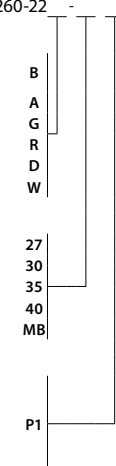

matte black (CM-085) with matte white interior



brushed aluminum (CM-012)



brushed rose gold (CM-046)



brushed brass (CM-047)



distressed brass (CM-096)

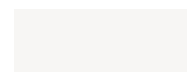

gloss white (CM-054)





matte black w/matte white interior



gloss white



Veris was a concept we started exploring ten years ago. Two offset layers of petals simultaneously shield the light source while allowing reflected light to wash the inside petals, creating a dramatic ambient luminaire. The form materializes through a series of processes that utilize cutting edge CNC laser technology but still rely on skilled hand-rolling and bending of the aluminum petals.

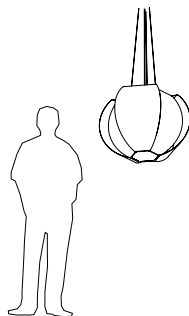

Veris 34 pendant

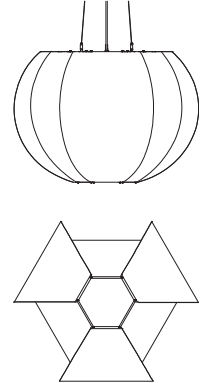
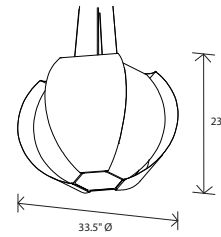

Dimensions: 33.5" Ø, 23"
Product weight: 8 lb
Suitable for a sloped ceiling

Integrated LED Specifications

Light output: 2815 Lumens (source)
Light color: 2700 K, 3000 K, 3500 K or 4000 K
Color accuracy: 90+ CRI
Power usage: 32.5 W
Dimmable (see driver below)
Driver housed in extended canopy
Driver dimensions: 3.3" x 2.4" x 1", included

E26 Medium Base Specifications

Lamping: 3x E26 base, type A lamp, 60 W max each
Input voltage: 250 V AC max
Bulbs not included

Textured Black (CM-049) extended round canopy with SVT-3 Cable, Black (CM-039) and 1/16" Stainless Steel Cables (CM-053)
Canopy dimensions: 5" Ø, 2"

See website for more canopy information
Field adjustable drop length: 1'0" min - 8'0" max
Specifications subject to change

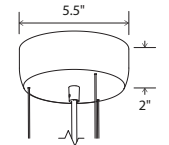

extended-profile round canopy with black SVT-3 cable and steel cables



MATERIAL & FINISH OPTIONS

Veris 34 part # 06-260-34

Shade Material

matte black (CM-085) with matte white interior
brushed aluminum (CM-012)
brushed rose gold (CM-046)
brushed brass (CM-047)
distressed brass (CM-096)
gloss white (CM-054)

Lamping

2700 K LED
3000 K LED
3500 K LED
4000 K LED
medium base E26 socket

Driver (LED version only)

AC Input Voltage Range: 120-277 V
120 V input:
TRIAC, ELV & 0-10 V dimmable
240 & 277 V input:
only 0-10 V dimmable

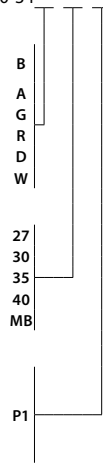

matte black (CM-085) with matte white interior



brushed aluminum (CM-012)



brushed rose gold (CM-046)



brushed brass (CM-047)



distressed brass (CM-096)

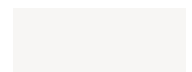

gloss white (CM-054)



Levis S / L
pendant

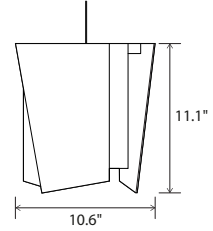
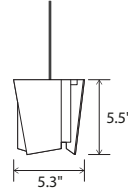

Dimensions: 5.3" Ø, 5.5" H
 Materials: polymer, veneer, aluminum
 Product weight: 1 lb
 Light source: integrated LED
 Light output: 345 Lumens (source)
 Light color*: 2700 K or 3500 K
 Color accuracy: 90+ CRI
 Power usage: 3.2 W
 Dimmable (see driver below)
 Driver location: must be housed in J-box
 Driver dimensions: 2" x 1.3" x 1", included
 Brushed aluminum (CM-006) low-profile square canopy with white braided cord included
 Canopy dimensions: 4.5" x 4.5", 0.38"
 Must use included external LED driver (2.25" x 1.5" x 1")

Accent pendants can be clustered by using multi-point round canopy or multi-point linear canopy
 See website for more canopy information
 6'-0" drop length, field adjustable
 Suitable for a sloped ceiling
 Wood grain will vary
 Specifications subject to change

Dimensions: 10.6" Ø, 11.1"
 Materials: polymer, veneer and aluminum
 Product weight: 7 lb
 Suitable for a sloped ceiling
Integrated LED Specifications
 Light output: 1250 Lumens (source)
 Light color*: 2700 K or 3500 K
 Color accuracy: 90+ CRI
 Power usage: 13 W
 Dimmable (see driver below)
 Brushed aluminum (CM-006) extended-profile square canopy with white braided cord included
 Canopy dimensions: 4.5" x 4.5", 1.8"
 Canopy required to house LED driver (3.3" x 1.6" x 1.0")
 See website for more canopy information
 6'-0" drop length, field adjustable

Medium Base Specifications
 Lamping: E26 base, type A lamp, 60 W max
 Bulb not included
 Input voltage: 250 V AC Max
 White (CM-060) low-profile round canopy with clear SVT cord included
 Canopy dimensions: 5.5"Ø, 0.38"
 72" drop length, field adjustable
 Specifications subject to change

MATERIAL & FINISH OPTIONS

Levis accent part #: 06-100 -

<i>Shade</i>		
frosted polymer (CM-024)	F	
beech wood veneer (CM-019)	B	
brushed aluminum (CM-012)	A	
<i>Lamping</i>		
2700 K LED	27	
3500 K LED	35	
<i>Driver</i>		
120 V AC input voltage TRIAC, ELV, or 0-10V dimmable	P1	

*Available in 3000K, 4000K and other color temperatures upon request

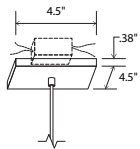

Levis S:
low-profile square canopy with clear braided cord

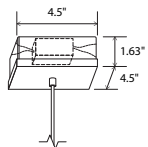

Levis L Integrated LED:
extended-profile square canopy with clear braided cord

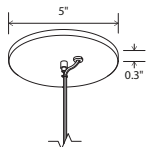

Levis L E26:
low-profile round canopy with white SPT cord and steel cable

MATERIAL & FINISH OPTIONS

Levis L part #: 06-170 -

<i>Shade</i>		
frosted polymer (CM-024)	F	
beech wood veneer (CM-019)	B	
brushed aluminum (CM-012)	A	
<i>Lamping</i>		
2700 K LED	27	
3500 K LED	35	
medium base E26 socket	MB	
<i>Driver (LED version only)</i>		
AC Input Voltage Range: 120-277 V		
120 V input: TRIAC, ELV & 0-10 V dimmable	P1	
240 & 277 V input: only 0-10 V dimmable		

*Available in 3000K, 4000K and other color temperatures upon request

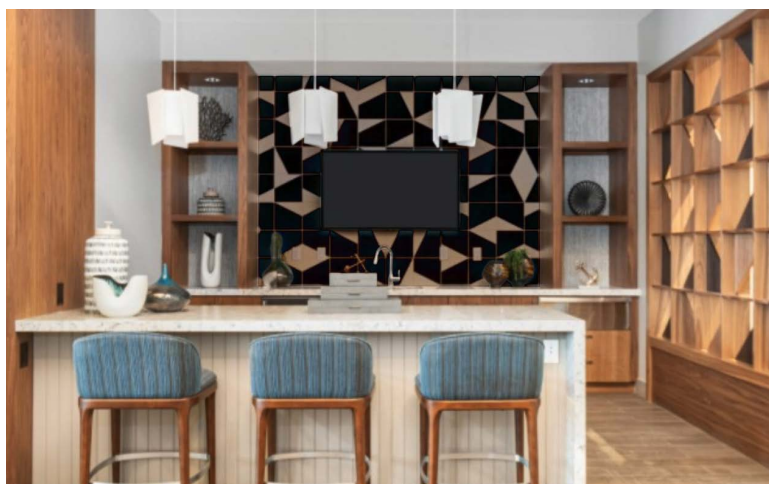

The Levis is simple and clean at first glance: complex upon closer review. The rhythm in the facets gives a dynamic feel from different vantage points, creating a sophistication to its presence.

*Nick Sheridan,
Designer*

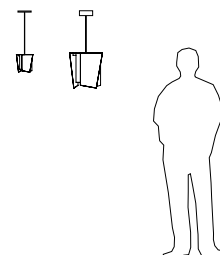

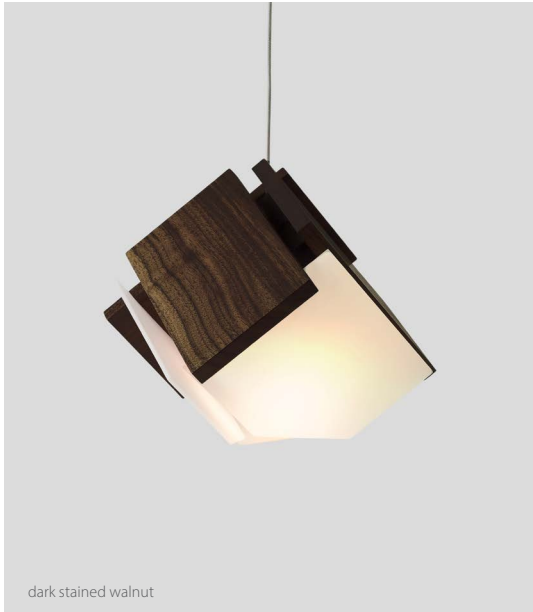

dark stained walnut

Mica S / L
pendant

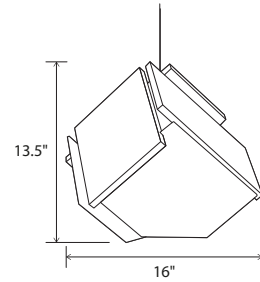
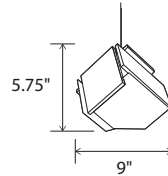

Dimensions: 9" Ø, 5.75"
 Materials: solid wood, polymer
 Product weight: 3 lb
 Light source: integrated LED
 Light output: 345 Lumens (source)
 Light color*: 2700 K or 3500 K
 Color accuracy: 90+ CRI
 Power usage: 3.2 W
 Dimmable (see driver below)
 Driver location: must be housed in J-box
 Driver dimensions: 2" x 1.3" x 1", included
 Brushed aluminum (CM-006) low-profile square canopy with white braided cord included
 Canopy dimensions: 4.5" x 4.5", 0.38"
 External LED driver (2.25" x 1.5" x 1")
 Accent pendants can be clustered by using multi-point round canopy or multi-point linear canopy
 See website for more canopy information
 6'-0" drop length, field adjustable
 Suitable for a sloped ceiling
 Wood grain will vary
 Specifications subject to change



MATERIAL & FINISH OPTIONS

Mica accent part #: 06-160

Wood Body	W	
walnut (CM-001)	D	
dark stained walnut (CM-002)		
Lamping		
2700 K LED	27	
3500 K LED	35	
Driver		
120 V AC input voltage	P1	
TRIAC, ELV, or 0-10V dimmable		

Includes: frosted polymer (CM-024)

*Available in 3000K, 4000K and other color temperatures upon request

Dimensions: 16" Ø, 13.5"
 Materials: solid wood, polymer
 Product weight: 8 lb
 Suitable for a sloped ceiling
Integrated LED Specifications
 Light output: 1250 Lumens (source)
 Light color*: 2700 K or 3500 K
 Color accuracy: 90+ CRI
 Power usage: 13 W
 Dimmable (see driver below)
 Brushed aluminum (CM-006) extended-profile square canopy with white braided cord included
 Canopy dimensions: 4.5" x 4.5", 1.8"
 Canopy required to house LED driver (3.3" x 1.6" x 1.0")
 See website for more canopy information
 6'-0" drop length, field adjustable
Medium Base Specifications
 Lamping: E26 base, type A lamp, 60 W max
 Bulb not included
 Input voltage: 250 V AC max
 White (CM-060) low-profile round canopy with clear SVT cord included
 Canopy dimensions: 5.5"Ø, 0.3"
 72" drop length, field adjustable



MATERIAL & FINISH OPTIONS

Mica L part #: 06-180

Wood Body	W	
walnut (CM-001)	D	
dark stained walnut (CM-002)		
Lamping		
2700 K LED	27	
3500 K LED	35	
medium base E26 socket	MB	
Driver (LED version only)		
AC Input Voltage Range: 120-277 V		
120 V input: TRIAC, ELV & 0-10 V dimmable	P1	
240 & 277 V input: only 0-10 V dimmable		

Includes: frosted polymer (CM-024)

*Available in 3000K, 4000K and other color temperatures upon request

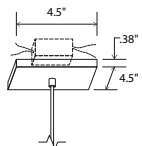

Mica S:
low-profile square canopy with clear braided cord

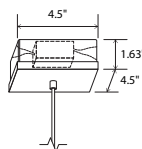

Mica L Integrated LED:
extended-profile square canopy with clear braided cord

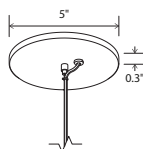

Mica L E26:
low-profile round canopy with white SPT cord and steel cable

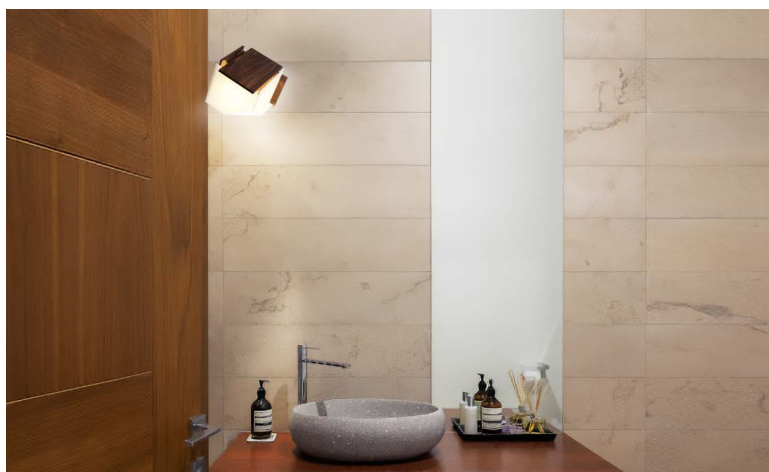

walnut (CM-001)

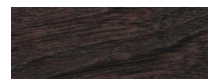

dark stained walnut (CM-002)

The Mica is simply a cube, which has been carefully deconstructed to a sculptural state. By way of the fixture's orientation and petal material composition, it exudes a certain organic symmetry. The Mica pendant acts as a beautiful node, creating a sense of space marked with an ambient glow.

*Nick Sheridan,
Designer*

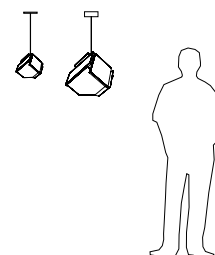

ClauDo
accent pendant

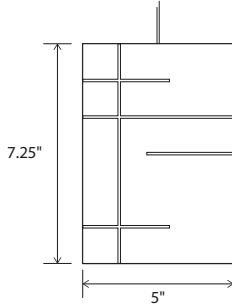

Dimensions: 5" x 5", 7.25"
 Materials: solid wood, polymer
 Product weight: 3 lb
 Light source: integrated LED
 Light output: 345 Lumens (source)
 Light color*: 2700 K or 3500 K
 Color accuracy: 90+ CRI
 Power usage: 3.2 W
 Dimmable (see driver below)
 Driver location: must be housed in J-box
 Driver dimensions: 2" x 1.3" x 1", included
 Brushed aluminum (CM-006) low-profile square canopy with white braided cord included
 Must use included external LED driver (2.25" x 1.5" x 1")
 Canopy dimensions: 4.5" x 4.5", 0.38"
 Accent pendants can be clustered by using multi-point round canopy or multi-point linear canopy
 See website for more canopy information
 6'-0" drop length, field adjustable
 Suitable for a sloped ceiling
 Wood grain will vary
 Specifications subject to change

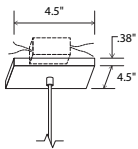

low-profile square canopy



walnut (CM-001)



dark stained walnut (CM-002)

MATERIAL & FINISH OPTIONS

ClauDo part #: 06-110-

Wood Body	
walnut (CM-001)	W
dark stained walnut (CM-002)	D
Lamping	
2700 K LED	27
3500 K LED	35
Driver	
120 V AC input voltage	P1
TRIAC, ELV, or 0-10V dimmable	

Includes frosted polymer (CM-024)

Also available in a sconce version

*Available in 3000K, 4000K and other color temperatures upon request



walnut

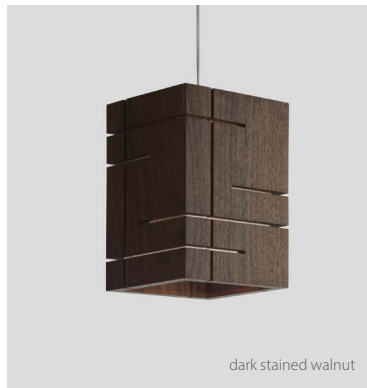

dark stained walnut

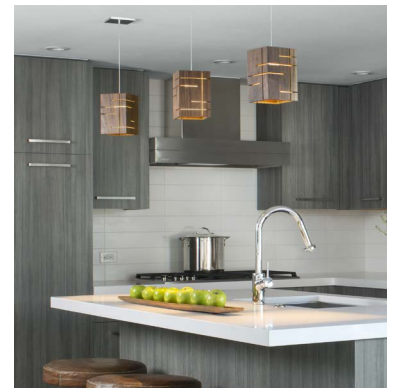

The ClauDo showcases the beautiful natural walnut wood grain and sets it against the rigorous slits cut in each face as they wrap around the simple, clean shade form. A beautiful glow emanates from each slit, showing the striking rectilinear composition, in which all four sides are unique.

Nick Sheridan,
Designer

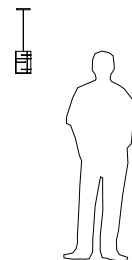



walnut, brushed aluminum



walnut, brushed aluminum



The Salix pendant's materials and proportions are in perfect harmony. The brushed aluminum set against the oiled walnut in this fixture still feels strikingly fresh and beautiful after years of production.

Nick Sheridan,
Designer

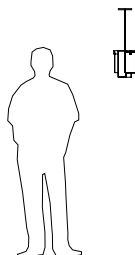

Salix

accent pendant

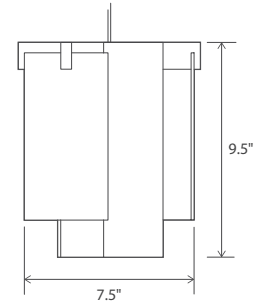

- Dimensions: 7.5" x 7.5", 9.0"
- Materials: solid wood, polymer, aluminum
- Product weight: 3 lb
- Light source: integrated LED
- Light output: 345 Lumens (source)
- Light color*: 2700 K or 3500 K
- Color accuracy: 90+ CRI
- Power usage: 3.2 W
- Dimmable (see driver below)
- Driver location: must be housed in J-box
- Driver dimensions: 2" x 1.3" x 1", included
- Brushed aluminum (CM-006) low-profile square canopy with white braided cord included
- Canopy dimensions: 4.5" x 4.5", 0.38"
- Must use included external LED driver (2.25" x 1.5" x 1")
- Accent pendants can be clustered by using multi-point round canopy or multi-point linear canopy
- See website for more canopy information
- 6'-0" drop length, field adjustable
- Suitable for a sloped ceiling
- Wood grain will vary
- Specifications subject to change

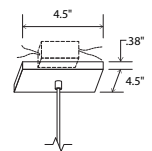

low-profile square canopy



MATERIAL & FINISH OPTIONS

Salix part # 06-120	
Wood Body	W
walnut (CM-001)	
Metal Finish	A
brushed aluminum (CM-012)	
Lamping	27
2700 K LED	
3500 K LED	35
Driver	P1
120 V AC input voltage	
TRIAC, ELV, or 0-10V dimmable	



walnut (CM-001)



brushed aluminum (CM-012)

Includes: frosted polymer (CM-024)

*Available in 3000K, 4000K and other color temperatures upon request

Plura
pendant



matte black w/white matte interior, walnut

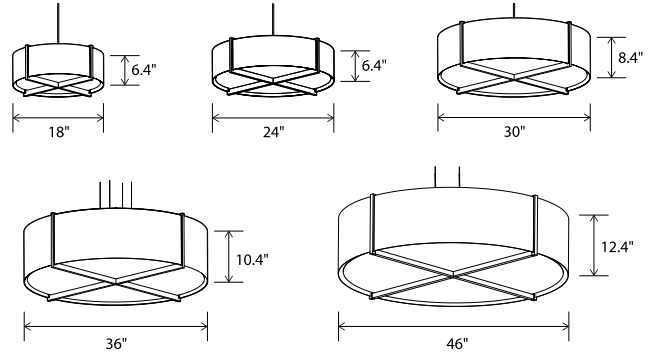

Dimensions:

- Plura 18: 18" Ø, 6.4"
- Plura 24: 24" Ø, 6.4"
- Plura 30: 30" Ø, 8.4"
- Plura 36: 36" Ø, 10.4"
- Plura 46: 46" Ø, 12.4"

Materials: solid wood, polymer

Product weight:

- Plura 18: 5 lb
- Plura 24: 6 lb
- Plura 30: 9 lb
- Plura 36: 13 lb
- Plura 46: 20 lb

Integrated LED Specifications

Light output:

- Plura 18 & 24: 1690 Lumens (source)
- Plura 30, 36, & 46: 2815 Lumens (source)

Light color: 2700 K, 3000 K, 3500 K, or 4000 K

Color accuracy: 90+ CRI

Power usage:

- Plura 18 & 24: 19.5 W
- Plura 30, 36, & 46: 32.5 W

Dimmable (see driver below)

Plura 18 & 24 driver location:
must be housed in J-box

Driver dimensions: 3.3" x 1.6" x 1", included

Plura 30, 36, & 46 driver location:
housed in canopy

GU-24 Base Specifications

Light source:

- Plura 18 & 24: 2x GU-24 base socket
- Plura 30, 36, & 46: 4x GU-24 base socket

Lamping:

- Plura 18 & 24: 2x GU-24 base self-ballasted bulbs, 18 W max each
- Plura 30, 36, & 46: 4x GU-24 base self-ballasted bulbs, 18 W max each

Bulbs not included

Input voltage: 300 V AC max

See at left for canopy information
96" drop length, field adjustable
Suitable for a sloped ceiling
Wood grain will vary
Specifications subject to change



MATERIAL & FINISH OPTIONS

Plura pendant part # 06-230

Size		
18" Ø	18	
24" Ø	24	
30" Ø	30	
36" Ø	36	
46" Ø	46	
Wood Body		
walnut (CM-001)	W	
dark stained walnut (CM-002)	D	
white washed oak (CM-095)	O	
Shade Material		
frosted polymer (CM-051)	F	
matte black (CM-085) with matte white interior	B	
brushed aluminum (CM-012)	A	
brushed rose gold (CM-046)	G	
brushed brass (CM-047)	R	
distressed brass (CM-096)	D	
gloss white (CM-054)	W	
Lamping		
2700 K LED	27	
3000 K LED	30	
3500 K LED	35	
2700 K LED	40	
GU-24 base sockets	GU	
Driver (LED version only)		
AC Input Voltage Range: 120-277 V		
120 V input: TRIAC, ELV & 0-10 V dimmable		
240 & 277 V input: only 0-10 V dimmable		
	P1	

Includes: frosted polymer (CM-051)

Also available in a flush mount version

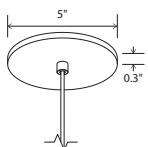

Plura 18 & Plura 24:
textured white (CM-060) low-profile round canopy with white SVT

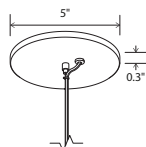

Plura 30 GU-24 Base Sockets:
textured white (CM-060) low-profile round canopy clear SPT with steel cable

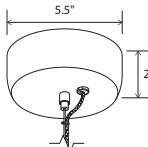

Plura 30 Integrated LED:
textured white (CM-060) extended round canopy, clear SPT with steel cable

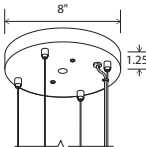

Plura 36 & 46:
textured white (CM-060) 8" round canopy, clear SPT with steel cable



Plura 36, dark stained walnut, frosted polymer

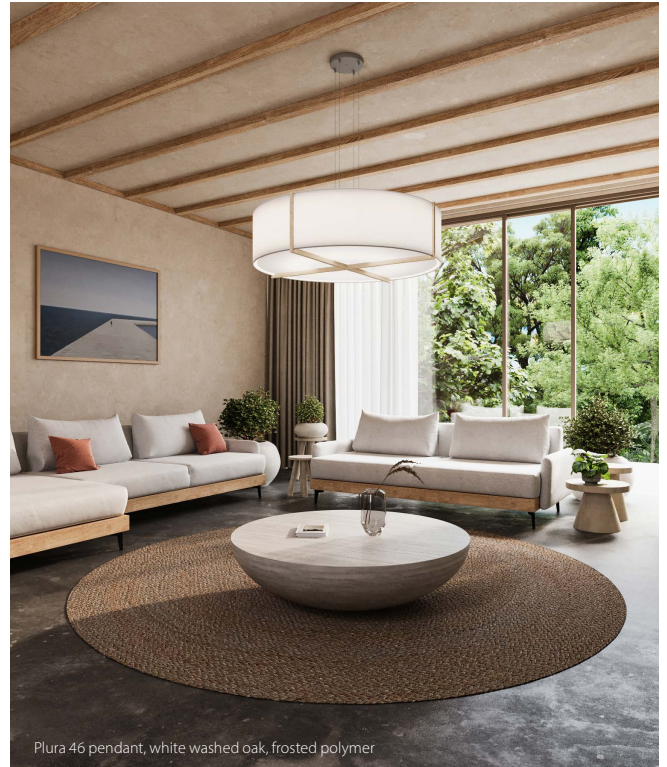

Plura 46 pendant, white washed oak, frosted polymer

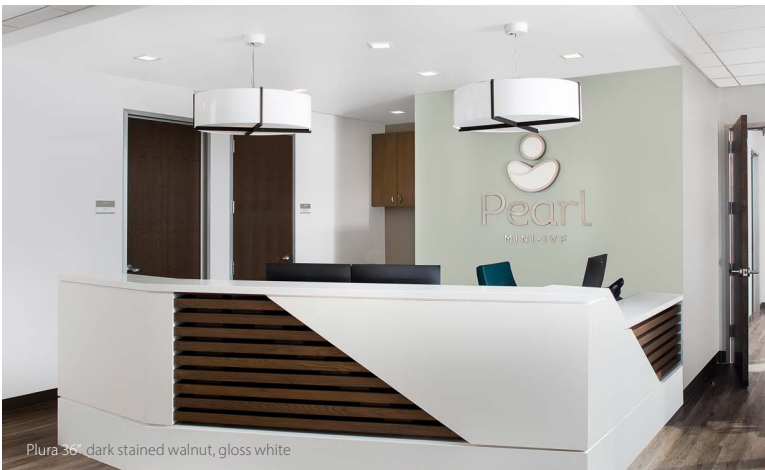

Plura 36, dark stained walnut, gloss white

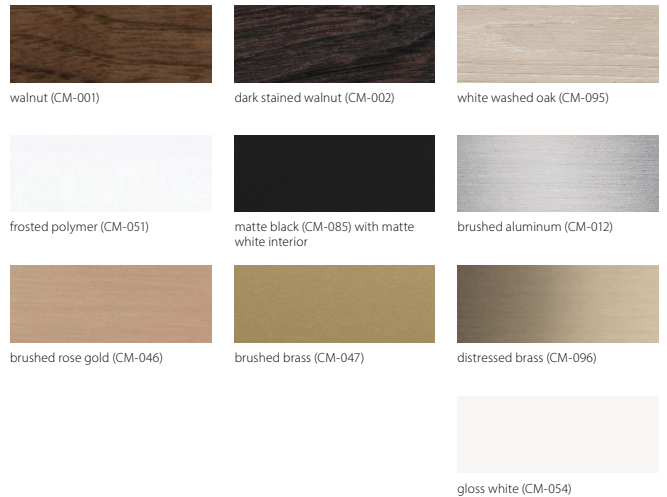

The Plura is a simple, straight forward fixture that is excellently executed. With the Plura it was about resolving the seams and edges and their relationships to one another. The result is a scalable fixture that has a sharp, sophisticated feel.

Nick Sheridan,
Designer

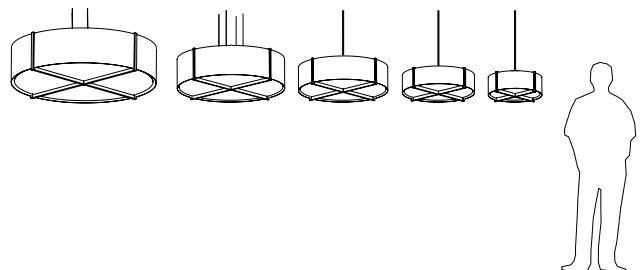



Plura flush mount, walnut

Flush Mount



Casia 14

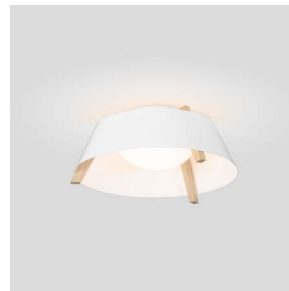

Casia 18



Casia 22



Plura



Volo



Casia 14
flush mount

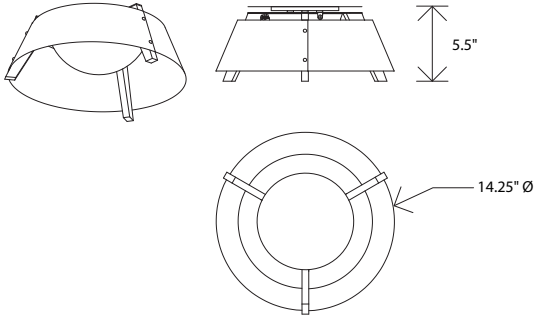

Dimensions: 14.25" Ø, 5.5"
 Product weight: 3 lb
 Light Color Options*:
 2700 K - 831 Lumens (source)
 3500 K - 873 Lumens (source)
 Color accuracy: 90+ CRI
 Power usage: 10 W
 Dimmable (see power options below)
 Wood grain will vary
 Specifications subject to change
 JA8-2019 Compliant



gloss white, white washed oak



matte black (CM-085)

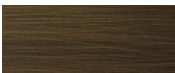

distressed brass (CM-009)

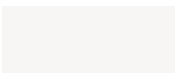

gloss white (CM-054)



walnut (CM-001)



dark stained walnut (CM-002)



white washed oak (CM-095)

MATERIAL & FINISH OPTIONS

Casia 14 part #: 08-110-14

Shade Material	B	
matte black (CM-085) with matte white interiors	D	
distressed brass (CM-009)	W	
gloss white (CM-054)		
Wood Body	W	
walnut (CM-001)	D	
dark stained walnut (CM-002)	O	
white washed oak (CM-095)		
Lamping	27	
2700 K LED	35	
3500 K LED		
Power Option	P1	
120-277 V AC input voltage		
TRIAC and ELV dimming		

Includes: white glass diffuser (CM-109)

Available in a pendant version

*Available in 3000K, 4000K and other color temperatures upon request



distressed brass, walnut

Casia is a fresh and innovative approach to a flush mount light fixture. Each carefully selected material plays an integral role in the aesthetic design and performance. The wood arms, metal shade, and glass diffuser combine to create a minimalist form well suited for a modern environment or a more traditional space. The 14" version works well in bathrooms, closets, narrow corridors, and smaller kitchens. The 18" and 22" sizes are incredibly dynamic and work well in different environments such as commercial, residential, and hospitality applications.

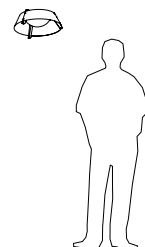

Casia 18

flush mount

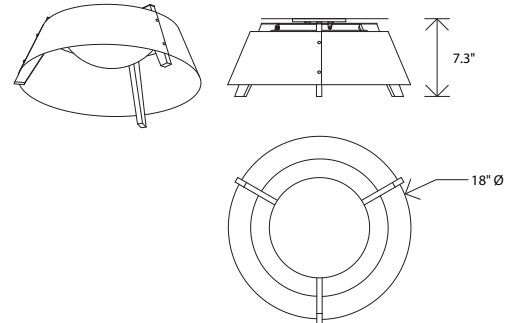

Dimensions: 18" Ø, 7.3"
 Product weight: 4 lb
 Light Color Options*:
 2700 K - 1310 Lumens (source)
 3500 K - 1378 Lumens (source)
 Color accuracy: 90+ CRI
 Power usage: 15 W
 Dimmable (see power options below)
 Wood grain will vary
 Specifications subject to change
 JA8-2019 Compliant



MATERIAL & FINISH OPTIONS

Casia 18 part # 08-110-18

Shade Material
 matte black (CM-085) with
 matte white interior
 distressed brass (CM-009)
 gloss white (CM-054)

Wood Body
 walnut (CM-001)
 dark stained walnut (CM-002)
 white washed oak (CM-095)

Lamping
 2700 K LED
 3500 K LED

Power Option
 120-277 V AC input voltage
 TRIAC and ELV dimming

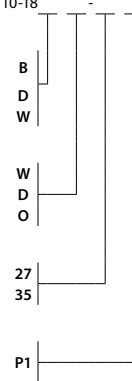

matte black (CM-085)

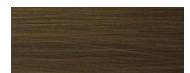

distressed brass (CM-009)

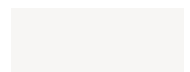

gloss white (CM-054)



walnut (CM-001)



dark stained walnut (CM-002)



white washed oak (CM-095)



Casia is a fresh and innovative approach to a flush mount light fixture. Each carefully selected material plays an integral role in the aesthetic design and performance. The wood arms, metal shade, and glass diffuser combine to create a minimalist form well suited for a modern environment or a more traditional space. The 14" version works well in bathrooms, closets, narrow corridors, and smaller kitchens. The 18" and 22" sizes are incredibly dynamic and work well in different environments such as commercial, residential, and hospitality applications.

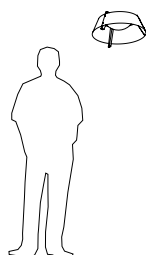



Casia 22
flush mount



matte black with white matte, dark stained walnut

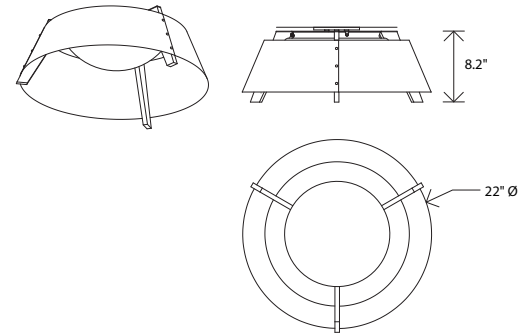

Dimensions: 21.5" Ø, 8.2"
Product weight: 5 lb
Light Color Options*:
2700 K - 1981 Lumens (source)
3500 K - 2083 Lumens (source)
Color accuracy: 90+ CRI
Power usage: 23 W
Dimmable (see power options below)
Wood grain will vary
Specifications subject to change
JA8-2019 Compliant



MATERIAL & FINISH OPTIONS

Casia 22 part # 08-110-22

Shade Material		
matte black (CM-085) with matte white interior	B	
distressed brass (CM-009)	D	
gloss white (CM-054)	W	
Wood Body		
walnut (CM-001)	W	
dark stained walnut (CM-002)	D	
white washed oak (CM-095)	O	
Lamping		
2700 K LED	27	
3500 K LED	35	
Power Option		
120-277 V AC input voltage TRIAC and ELV dimming	P1	



matte black (CM-085)

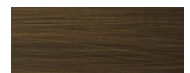

distressed brass (CM-009)

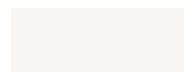

gloss white (CM-054)



walnut (CM-001)



dark stained walnut (CM-002)



white washed oak (CM-095)



dark stained walnut details

Casia is a fresh and innovative approach to a flush mount light fixture. Each carefully selected material plays an integral role in the aesthetic design and performance. The wood arms, metal shade, and glass diffuser combine to create a minimalist form well suited for a modern environment or a more traditional space. The 14" version works well in bathrooms, closets, narrow corridors, and smaller kitchens. The 18" and 22" sizes are incredibly dynamic and work well in different environments such as commercial, residential, and hospitality applications.

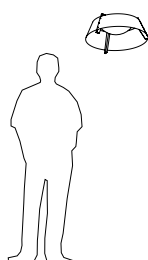

Includes: white glass diffuser (CM-109)

Available in a pendant version

*Available in 3000K, 4000K and other color temperatures upon request



Plura flush mount, walnut, matte black with matte white interior



dark stained walnut, frosted polymer



walnut, distressed brass



walnut, brushed aluminum

The Plura is a simple, straight forward fixture that is excellently executed. With the Plura it was about resolving the seams and edges and their relationships to one another. The result is a scalable fixture that has a sharp, sophisticated feel.

Nick Sheridan,
Designer



walnut (CM-001)

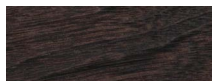

dark stained walnut (CM-002)



white washed oak (CM-095)



frosted polymer (CM-051)



matte black (CM-085) with matte white interior



brushed aluminum (CM-012)



brushed rose gold (CM-046)



brushed brass (CM-047)



distressed brass (CM-096)

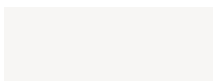

gloss white (CM-054)

Plura

flush mount

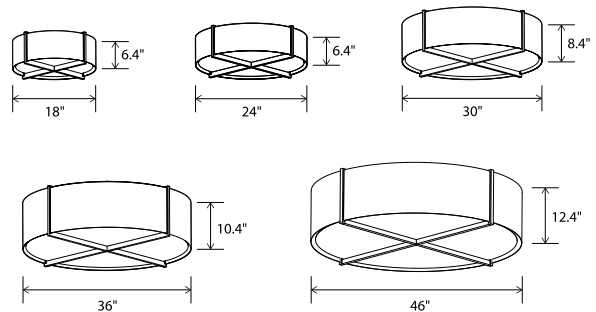

Dimensions:

Plura 18: 18" Ø, 7.8"

Plura 24: 24" Ø, 7.8"

Plura 30: 30" Ø, 9.8"

Plura 36: 36" Ø, 11.8"

Plura 46: 46" Ø, 13.8"

Materials: solid wood, polymer

Product weight:

Plura 18: 5 lb

Plura 24: 6 lb

Plura 30: 9 lb

Plura 36: 13 lb

Plura 46: 20 lb

Integrated LED Specifications

Light output:

Plura 18 & 24: 1690 Lumens (source)

Plura 30, 36, & 46: 2815 Lumens (source)

Light color: 2700 K, 3000 K, 3500 K, or 4000 K

Color accuracy: 90+ CRI

Power usage:

Plura 18 & 24: 19.5 W

Plura 30, 36, & 46: 32.5 W

Dimmable (see driver below)

GU-24 Base Specifications

Light source:

Plura 18 & 24: 2x GU-24 base socket

Plura 30, 36, & 46: 4x GU-24 base socket

Lamping:

Plura 18 & 24: 2x GU-24 base self-ballasted bulbs, 18 W max each

Plura 30, 36, & 46: 4x GU-24 base self-ballasted bulbs, 18 W max each*

Bulbs not included

Input voltage: 300 V AC max

Input voltage: 300 V AC max

Input voltage: 300 V AC max

Input voltage: 300 V AC max

Input voltage: 300 V AC max

Input voltage: 300 V AC max

Input voltage: 300 V AC max

Input voltage: 300 V AC max

Input voltage: 300 V AC max

Input voltage: 300 V AC max

Input voltage: 300 V AC max

Input voltage: 300 V AC max

Input voltage: 300 V AC max

Input voltage: 300 V AC max

Input voltage: 300 V AC max

Input voltage: 300 V AC max

Input voltage: 300 V AC max

Input voltage: 300 V AC max

Input voltage: 300 V AC max

Input voltage: 300 V AC max

Input voltage: 300 V AC max

Input voltage: 300 V AC max

Input voltage: 300 V AC max

Input voltage: 300 V AC max

Input voltage: 300 V AC max

Input voltage: 300 V AC max

Input voltage: 300 V AC max

MATERIAL & FINISH OPTIONS

Plura flush mount part # 08-100

Size	
18" Ø	18
24" Ø	24
30" Ø	30
36" Ø	36
46" Ø	46
WoodBody	
walnut (CM-001)	W
dark stained walnut (CM-002)	D
white washed oak (CM-095)	O
Shade Material	
frosted polymer (CM-051)	F
matte black (CM-085) with matte white interior	B
brushed aluminum (CM-012)	A
brushed rose gold (CM-046)	G
brushed brass (CM-047)	R
distressed brass (CM-096)	D
gloss white (CM-054)	W
Lamping	
2700 K LED	27
3000 K LED	30
3500 K LED	35
4000 K LED	40
GU-24 base sockets	GU
Driver (LED version only)	
AC Input Voltage Range: 120-277 V	
120 V input: TRIAC, ELV & 0-10 V dimmable	P1
240 & 277 V input: only 0-10 V dimmable	

Includes: frosted polymer (CM-051)

Emergency backup option available upon request

Also available in a pendant version

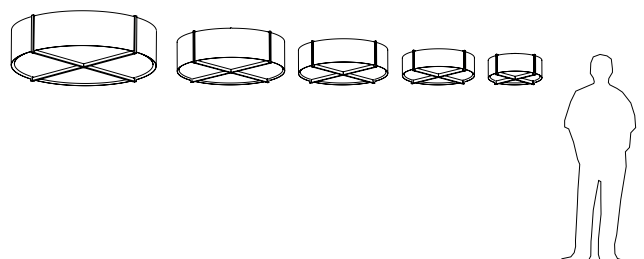



Volo flush mount, deux

Volo
flush mount

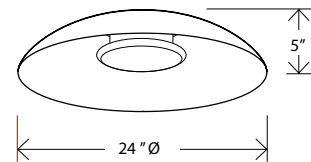

Dimensions: 24" Ø, 5"
 Product weight: 7 lb
 Light source: integrated LED
 Light output: 2625 Lumens (source)
 Output based on white shade interior
 Alternate finishes will reduce lumen output
 Light color: 2700 K, 3000 K, 3500 K, or 4000 K
 Color accuracy: 90+ CRI
 Power usage: 27 W
 Dimmable (see power options below)
 Wood grain will vary
 Specifications subject to change



MATERIAL & FINISH OPTIONS

Volo flush mount part # 08-120

Finish Options

noir	N
blanc	B
cava	C
deux	D
<i>Lamping</i>	
2700 K LED	27
3000 K LED	30
3500 K LED	35
4000 K LED	40

Power Option

AC Input Voltage Range: 120-277 V
 120 V input: TRIAC, ELV & 0-10 V dimmable
 240 & 277 V input: only 0-10 V dimmable

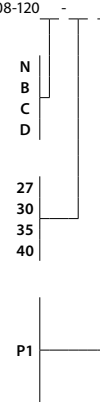

textured black powder coat (CM-049)

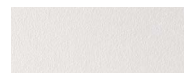

textured white powder coat (CM-060)

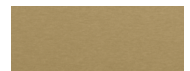

brushed brass (CM-120)



distressed brass (CM-117)



walnut (CM-001)



dark stained walnut (CM-002)



white washed oak (CM-095)



cava
white exterior, brushed brass interior, brass metal accents, and walnut disc

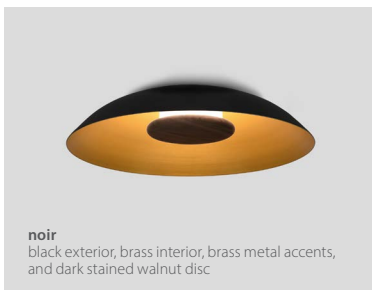

noir
black exterior, brass interior, brass metal accents, and dark stained walnut disc

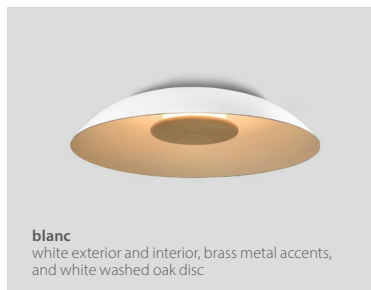

blanc
white exterior and interior, brass metal accents, and white washed oak disc



deux
black exterior, white interior, black metal accents, and walnut disc



noir, under view

The handcrafted Volo flush mount is a celebration of natural materials. The solid hardwood, brass finish, and aluminum showcase the purposeful design that went into each detail. The indirect LED light source emits light of beautiful quality.

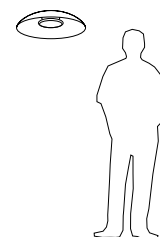



Outdoor Sconces

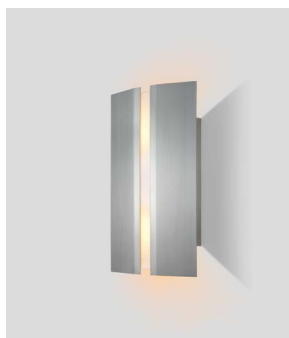

Rima Outdoor



Tersus Outdoor



Calx Outdoor



Ansa Outdoor



Acuo Outdoor



Rima Outdoor
sconce

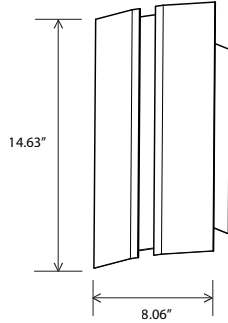

Dimensions: 14.63" x 8.06" x 3.71"
 Product weight: 2 lb (4 lb Stainless Steel)
 Light source: integrated LED
 Light output: see options below*
 Light color options:
 2700 K, 3000K, 3500 K, or 4000 K
 Color accuracy: 90+ CRI
 Power usage: 13 W (standard output)
 7 W (reduced output)
 UL listed for wet locations, suitable for indoor
 and outdoor use
 Specifications subject to change

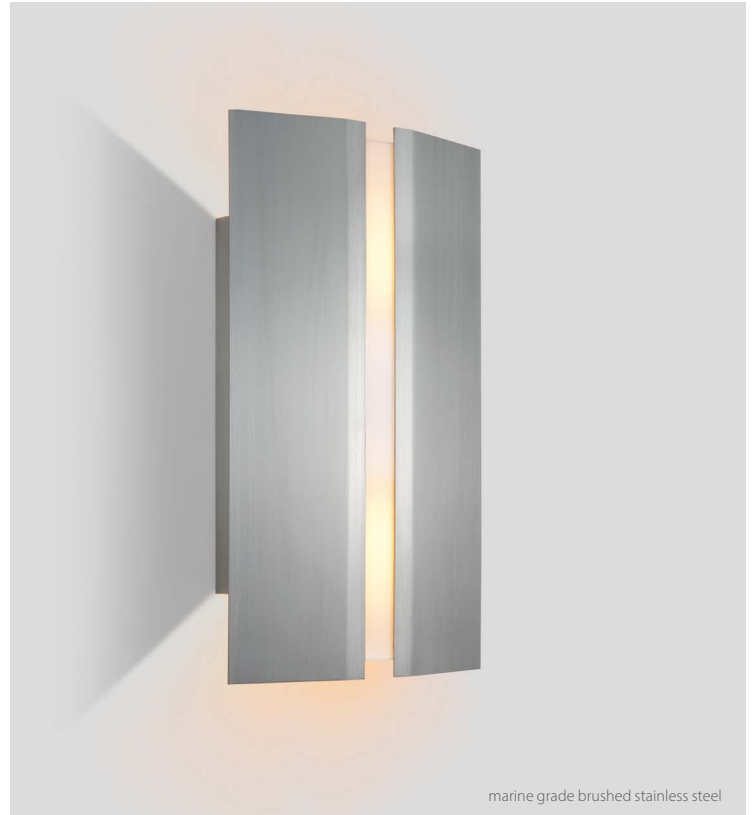

marine grade brushed stainless steel



marine grade brushed stainless steel (CM-102)



textured black powder coat (CM-099)

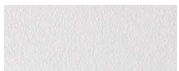

textured white powder coat (CM-100)

MATERIAL & FINISH OPTIONS

Rima outdoor part #: 03-310-

Shade Finish		
marine grade brushed stainless steel (CM-102)	S	
textured black powder coat (CM-099)	K	
textured white powder coat (CM-100)	Y	
Lamping		
2700 K LED	27	
3000 K LED	30	
3500 K LED	35	
4000 K LED	40	
Light Distribution and Driver Options*		
Uplight & Downlight		
Standard output - 1130 Lumens (source, at 2700 K)	P1	
120 V input: TRIAC, ELV & 0-10 V dimmable		
240 & 277 V input: only 0-10 V dimmable		
Reduced output - 540 Lumens (source, at 2700 K)	PR	
120 - 277 V input: non-dimmable		

Includes: frosted polymer (CM-051)



textured black powder coat

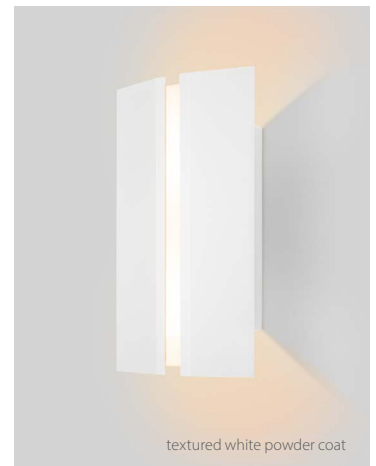

textured white powder coat

The Rima Outdoor sconce is an illuminating example of functional minimalism. The shade is distilled down to a few essential materials composing a sleek modern design that emits a beautiful quality of light.

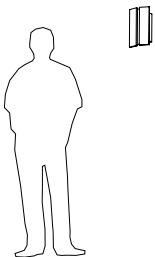



Tersus Outdoor
sconce

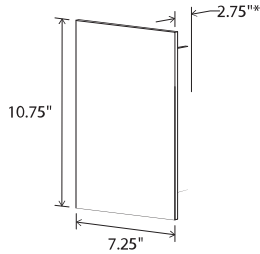

Dimensions: 10.75" x 7.25" x 2.75" (3.5" concrete)
 Product weight: 4 lb (9 lb concrete)
 Light source: integrated LED
 Light output: see options below
 Light color options: 2700 K, 3000K, 3500 K, or 4000 K
 Color accuracy: 90+ CRI
 Power usage: 14 W
 Dimmable (see options below)
 UL listed for wet locations, suitable for use indoor & outdoors
 Antique bronze and concrete finishes will vary
 Antique bronze is a living finish and will change over time
 depending on environmental conditions
 Specifications subject to change
 Custom backlit address or room numbers available



antique bronze



white concrete

marine grade brushed stainless steel

Cerno's Tersus Outdoor sconce is an existing design that we modified to withstand the elements. The materials and components were meticulously designed and engineered to comply and pass UL's wet location requirements.

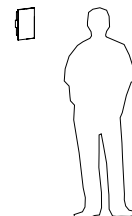

white concrete (CM-104)



black concrete (CM-105)



marine grade brushed stainless steel (CM-102)



antique bronze (CM-103)

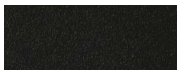

textured black powder coat (CM-099)

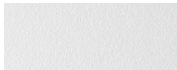

textured white powder coat (CM-100)



matte grey powder coat (CM-101)

MATERIAL & FINISH OPTIONS

Tersus outdoor part #: 03-242 -

Shade Material	
white concrete (CM-104)	W
black concrete (CM-105)	B
marine grade brushed stainless steel (CM-102)	S
antique bronze (CM-103)	R
textured black powder coat (CM-099)	K
textured white powder coat (CM-100)	Y
matte grey powder coat (CM-101)	G
Lamping	
2700 K LED	27
3000 K LED	30
3500 K LED	35
4000 K LED	40
Light Distribution and Driver Options	
Uplight & Downlight	
120-277 V AC input voltage	
Standard output - 1130 Lumens (source)	
120 V input: TRIAC, ELV & 0-10 V dimmable	P1
240 & 277 V input: only 0-10 V dimmable	
Reduced output - 540 Lumens (source), nondimmable	PR
Downlight Only - Dark Sky Compliant*	
120-277 V AC input voltage	
Standard output - 1130 Lumens (source)	
120 V input: TRIAC, ELV & 0-10 V dimmable	D1
240 & 277 V input: only 0-10 V dimmable	
Reduced output - 540 Lumens (source), nondimmable	DR

*2700 K & 3000 K downlight only options are dark sky compliant

Includes: marine grade brushed stainless steel (CM-102) (except for Antique Bronze version)

J-box centered behind fixture

Calx Outdoor sconce

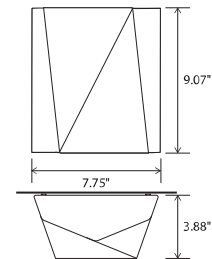

Dimensions: 9.07" x 7.75" x 3.88"
 Product weight: 2 lb
 Light source: integrated LED
 Light output: see options below
 Light color options: 2700 K, 3000K, 3500 K, or 4000 K
 Color accuracy: 90+ CRI
 Power usage: 14 W
 Dimmable (see options below)
 UL listed for wet locations, suitable for use indoor & outdoors
 Antique bronze finish will vary
 Antique bronze is a living finish and will change over time
 depending on environmental conditions
 Specifications subject to change
 Custom backlit address or room numbers available



MATERIAL & FINISH OPTIONS



Cerno's Calx Outdoor sconce is an existing design that we modified to withstand the elements. The materials and components were meticulously designed and engineered to comply and pass UL's wet location requirements.

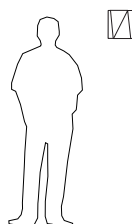

Calx outdoor sconce part #: 03-244	
Shade Material	
marine grade brushed stainless steel (CM-102)	S
antique bronze (CM-103)	R
textured black powder coat (CM-099)	K
textured white powder coat (CM-100)	Y
matte grey powder coat (CM-101)	G
Lamping	
2700 K LED	27
3000 K LED	30
3500 K LED	35
4000 K LED	40
Light Distribution and Driver Options	
Uplight & Downlight	
120-277 V AC input voltage	
Standard output - 1130 Lumens (source)	
120 V input: TRIAC, ELV & 0-10 V dimmable	P1
240 & 277 V input: only 0-10 V dimmable	
Reduced output - 540 Lumens (source), nondimmable	PR
Downlight Only - Dark Sky Compliant*	
120-277 V AC input voltage	
Standard output - 1130 Lumens (source)	
120 V input: TRIAC, ELV & 0-10 V dimmable	D1
240 & 277 V input: only 0-10 V dimmable	
Reduced output - 540 Lumens (source), nondimmable	DR

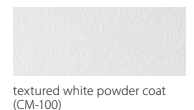

*2700 K & 3000 K downlight only options are dark sky compliant

Ansa Outdoor
sconce

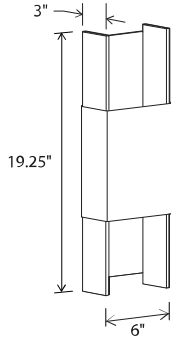

Dimensions: 19.25" x 6" x 3"
 Product weight: 5 lb
 Light source: integrated LED
 Light output: see options below
 Light color options:
 2700 K, 3000K, 3500 K, or 4000 K
 Color accuracy: 90+ CRI
 Power usage: 14 W
 Dimmable (see options below)
 UL listed for wet locations, suitable for use
 indoor and outdoors
 Antique bronze finish will vary
 Antique bronze is a living finish and will change
 over time depending on environmental conditions
 Specifications subject to change
 Custom backlit address or room numbers available



matte grey powder coat



antique bronze



textured white powder coat

Cerno's Ansa Outdoor sconce is an existing design that we modified to withstand the elements. The materials and components were meticulously designed and engineered to comply and pass UL's wet location requirements.



marine grade brushed stainless steel (CM-102)



antique bronze (CM-103)



textured black powder coat (CM-099)



textured white powder coat (CM-100)



matte grey powder coat (CM-101)

MATERIAL & FINISH OPTIONS

Ansa outdoor part #: 03-243

Shade Material

- marine grade brushed stainless steel (CM-102)
- antique bronze (CM-103)
- textured black powder coat (CM-099)
- textured white powder coat (CM-100)
- matte grey powder coat (CM-101)

Lamping

- 2700 K LED
- 3000 K LED
- 3500 K LED
- 4000 K LED

Light Distribution and Driver Options

Uplight & Downlight

- 120-277 V AC input voltage
- Standard output - 1130 Lumens (source)
- 120 V input: TRIAC, ELV & 0-10 V dimmable
- 240 & 277 V input: only 0-10 V dimmable
- Reduced output - 540 Lumens (source), nondimmable

S	-
R	-
K	-
Y	-
G	-
27	-
30	-
35	-
40	-
P1	-
PR	-

Includes: frosted polymer (CM-024)

J-box centered behind fixture

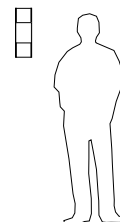

Acuo Outdoor sconce



Textured black powder coat



matte gray powder coat



textured white powder coat

Cerno's Acuo Outdoor sconce is an existing design that we modified to withstand the elements. The materials and components were meticulously designed and engineered to comply and pass UL's wet location requirements.

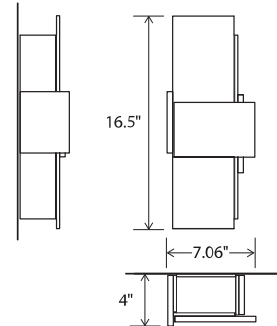
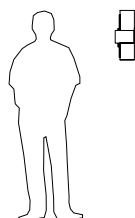

Dimensions: 16.5" x 7.06" x 4"
 Product weight: 6 lb
 Light source: integrated LED
 Light output: see options below
 Light color options:
 2700 K, 3000K, 3500 K, or 4000 K
 Color accuracy: 90+ CRI
 Power usage: 13 W
 Dimmable (see options below)
 UL listed for wet locations, suitable for use
 indoor and outdoors
 Specifications subject to change



MATERIAL & FINISH OPTIONS

Acuo outdoor sconce part #: 03-241

Shade Material

textured black powder coat (CM-099)
 textured white powder coat (CM-100)
 matte grey powder coat (CM-101)

Lamping

2700 K LED
 3000 K LED
 3500 K LED
 4000 K LED

Light Distribution and Driver Options

Uplight & Downlight

120-277 V AC input voltage
 Standard output - 1130 Lumens (source)
 120 V input: TRIAC, ELV & 0-10 V dimmable
 240 & 277 V input: only 0-10 V dimmable
 Reduced output - 540 Lumens (source),
 nondimmable

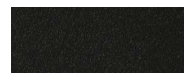
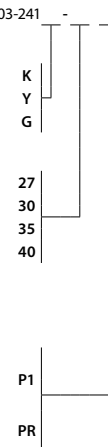

textured black powder coat
(CM-099)

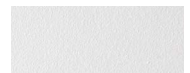

textured white powder coat
(CM-100)



matte grey powder coat
(CM-101)

Includes: frosted polymer (CM-024)

J-box centered behind fixture



Vanity Lighting



Allavo



Merus



Allavo
vanity sconce

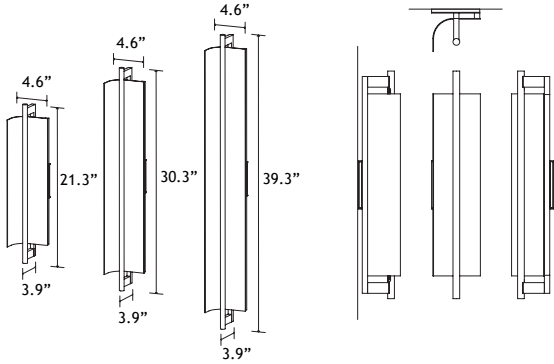

Allavo 22 dimensions: 21.3" x 4.6" x 3.9"

Allavo 31 dimensions: 30.3" x 4.6" x 3.9"

Allavo 40 dimensions: 39.3" x 4.6" x 3.9"

Allavo 22 weight: 2 lb

Allavo 31 weight: 2 lb

Allavo 40 weight: 3 lb

Light source: integrated LED

Allavo 22 light output: 780 Lumens (source)

Allavo 31 light output: 1170 Lumens (source)

Allavo 40 light output: 1560 Lumens (source)

Light color: 2700 K, 3000 K, 3500 K or 4000 K

Color accuracy: 90+ CRI

Allavo 22 power usage: 11 W

Allavo 31 power usage: 16 W

Allavo 40 power usage: 21 W

Dimmable (see driver below)

Driver location: must be housed in J-box

Allavo 22 driver dimensions: 2.63" x 1.25" x 0.8", included

Allavo 31 driver dimensions: 3.0" x 1.0" x 1.5", included

Allavo 40 driver dimensions: 2.82" x 2.5" x 1.2", included

Wood grain will vary

Specifications subject to change

The Allavo can be oriented as a vertical sconce or horizontal sconce. When oriented vertically, a right or left orientation can be achieved by flipping the fixture vertically



textured white, walnut



allavo 22", textured white, walnut



textured white, walnut, bottom details

MATERIAL & FINISH OPTIONS

Allavo part #: 03-250-

A -

Size

22

31

40

Metal Finish

textured black (CM-049) exterior with

textured white (CM-060) interior

textured white (CM-060) exterior/interior

Wood Finish

walnut (CM-001)

dark stained walnut (CM-002)

white washed oak (CM-095)

Lamping

2700 K LED

3000 K LED

3500 K LED

4000 K LED

Driver

120 V AC input voltage

TRIAC, ELV & 0-10 V dimming

277 V AC input voltage

TRIAC, ELV & 0-10 V dimming

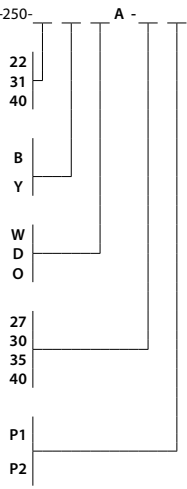

Includes: brushed aluminum (CM-006)

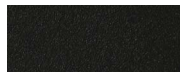

textured black powder coat (CM-049)

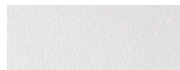

textured white powder coat (CM-060)



walnut (CM-001)

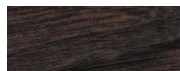

dark stained walnut (CM-002)



white washed oak (CM-095)

Cerno's product development team prioritized the utility of the Allavo vanity, while not ignoring the importance of the aesthetic. Drawing from our experience with product photography, we knew that a large diffuse light source was the key to achieving our goal. The novel design uses indirect lighting that bounces off a curved metal surface.

Cerno's signature use of wood is integrated seamlessly into a design we believe harmonizes usefulness and beauty.

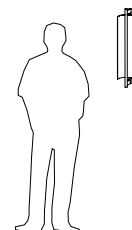



Merus 31", walnut



Merus 22", walnut



walnut, bottom details

Merus is a quintessential Cerno design. Clean, modern lines paired with a novel indirect light source compose a form that balances beauty and usefulness. Our team used Cerno's signature material palette of wood and metal.

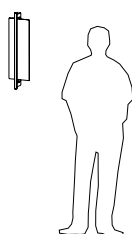

Merus

vanity sconce

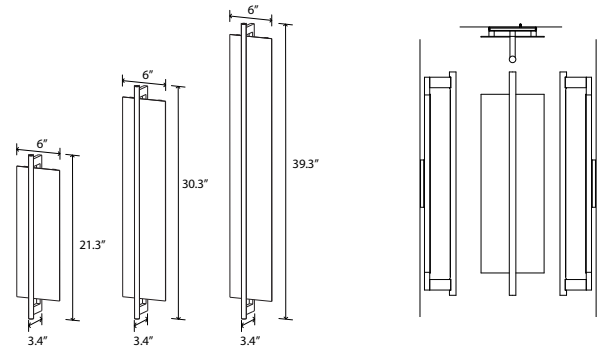

Merus 22 dimensions: 21.3" x 6" x 3.4"

Merus 31 dimensions: 30.3" x 6" x 3.4"

Merus 40 dimensions: 39.3" x 6" x 3.4"

Merus 22 weight: 2 lb

Merus 31 weight: 2 lb

Merus 40 weight: 3 lb

Light source: integrated LED

Merus 22 light output: 780 Lumens (source)

Merus 31 light output: 1170 Lumens (source)

Merus 40 light output: 1560 Lumens (source)

Light color: 2700 K, 3000 K, 3500 K or 4000 K

Color accuracy: 90+ CRI

Merus 22 power usage: 11 W

Merus 31 power usage: 16 W

Merus 40 power usage: 21 W

Dimmable (see driver below)

Driver location: must be housed in J-box

Merus 22 driver dimensions: 2.63" x 1.25" x 0.8", included

Merus 31 driver dimensions: 3.0" x 1.0" x 1.5", included

Merus 40 driver dimensions: 2.82" x 2.5" x 1.2", included

Wood grain will vary

Specifications subject to change



MATERIAL & FINISH OPTIONS

	Merus part #: 03-251-	B	A
Size			
22"			
31"			
40"			
Wood Finish			
walnut (CM-001)		W	
dark stained walnut (CM-002)		D	
white washed oak (CM-095)		O	
Lamping			
2700 K LED		27	
3000 K LED		30	
3500 K LED		35	
4000 K LED		40	
Driver			
120 V AC input voltage		P1	
TRIAC, ELV & 0-10 V dimming			
277 V AC input voltage		P2	
TRIAC, ELV & 0-10 V dimming			

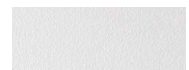

textured white powder coat (CM-060)



walnut (CM-001)



dark stained walnut (CM-002)

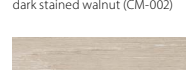

white washed oak (CM-095)

Includes:
textured white (CM-060) exterior and interior reflector
brushed aluminum (CM-006)



Sconces

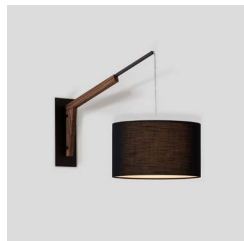

Talea



Rima



Via

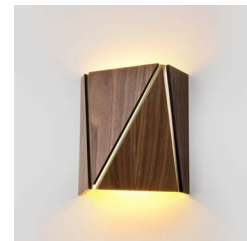

Calx sconce



Spero sconce



Penna sconce

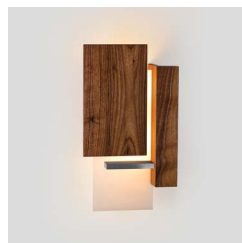

Vesper



Tempus



Acuo



Capio



Oris



Ora



tersus

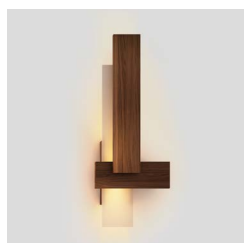

Sedo



Ansa

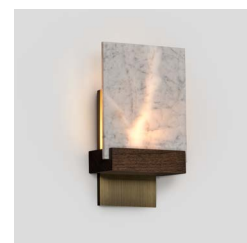

Fortis

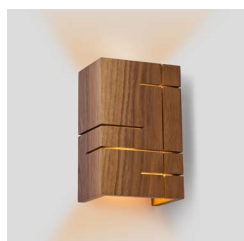

Clauco sconce



Libri



Levo



Talea, brushed aluminum, dark stained walnut, white linen,

Talea
articulate wall sconce



textured black, walnut, burlap

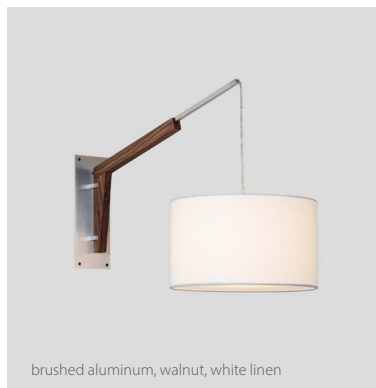

brushed aluminum, walnut, white linen

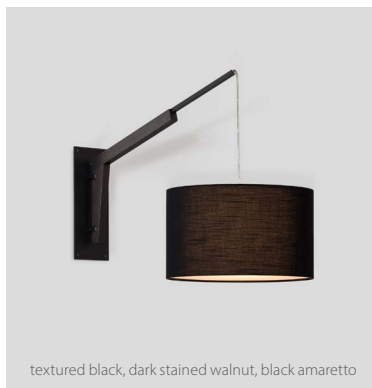

textured black, dark stained walnut, black amaretto

The adaptive and interactive features of the Talea introduced exciting challenges to the design process. I believe we found a balance that allows this fixture to thrive in a range of spaces and different applications. I am really pleased with how the design language turned out, specifically how the expressive hinge suggests its ability to swing, and how the wood to metal arm detailing suggests the arm can telescope. It's a beautiful mixture of utility and elegance.

Nick Sheridan,
Designer

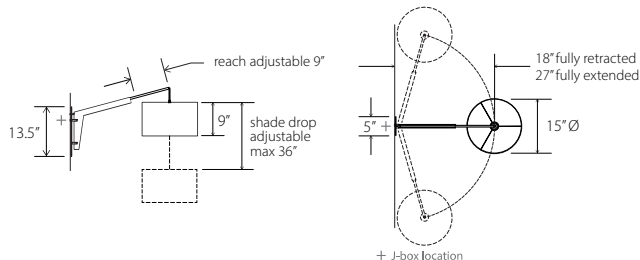
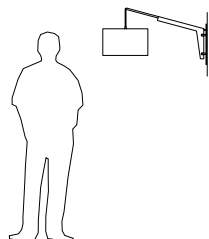

Dimensions: 18.38" x 5" x 34.75", 15" Ø shade
Materials: solid wood, metal
Product weight: 5 lb
Light source: medium base E26 socket
Lamping: E26 base, type A lamp, 60 W max
Bulb not included
Input voltage: 250 V AC max
Clear SVT-3 cord included
Top and bottom diffusers included (CM-051)
Wood grain will vary
Specifications subject to change



MATERIAL & FINISH OPTIONS

Talea part # 03-210

Metal Finish

brushed aluminum (CM-006) A
textured black powder coat (CM-049) B

Wood Body

walnut (CM-001) W
dark stained walnut (CM-002) D

Fabric Shade

burlap (CM-017) N
white linen (CM-016) L
black amaretto (CM-018) A



brushed aluminum (CM-006)



textured black powder coat (CM-049)



walnut (CM-001)



dark stained walnut (CM-002)



burlap (CM-017)



white linen (CM-016)



black amaretto (CM-018)

Includes: frosted polymer diffuser (CM-051)

SWING ARM LENGTH

Arm length (from the wall to center of shade) can be adjusted between 18" and 27"

DROP LENGTH

Max drop length from tip of extended arm to top of shade is 36"

SWING ARM ROTATION

Adjustable resistance in pivot hinge

For additional products that utilize the swing arm bracket, please see our Motus Swing Arm Bracket.

Patent # USD846180S1



Rima sconce, white washed oak



oil rubbed bronze

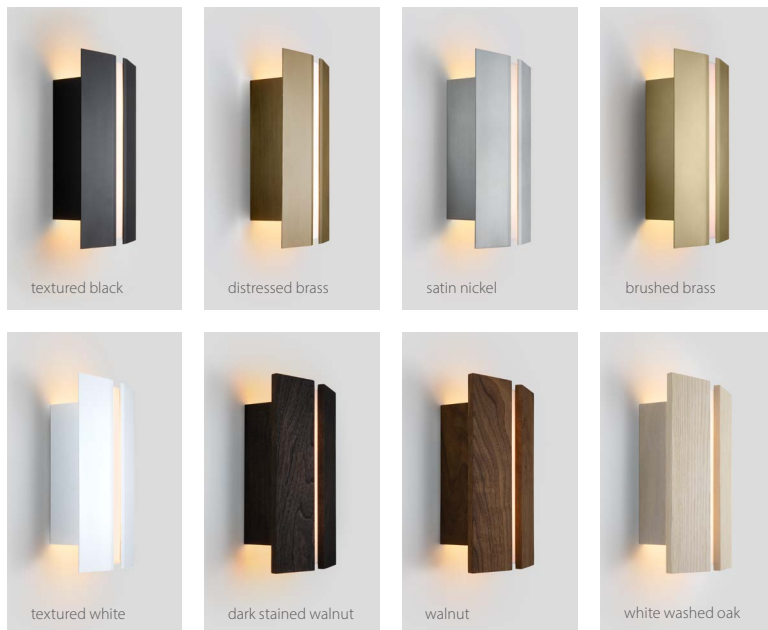

The Rima sconce is an illuminating example of functional minimalism. The shade is distilled down to a few essential materials composing a sleek modern design that emits a beautiful quality of light. The Rima is available in a variety of metal and wood finishes.

Rima
sconce

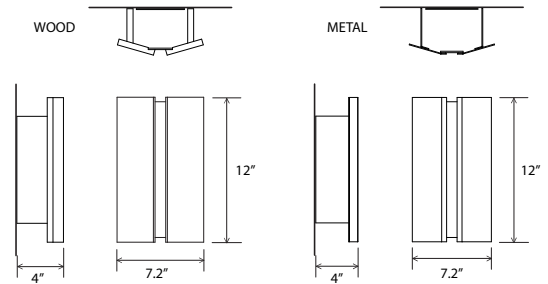

Dimensions: 12" x 7.2" x 4"
 Product weight: 3 lb
 Light source: integrated LED
 Light output: 1130 Lumens (source)
 Light color: 2700 K, 3000 K, 3500 K, or 4000 K
 Color accuracy: 90+ CRI
 Power usage: 14 W
 Wood grain will vary
 Specifications subject to change



walnut (CM-001)



dark stained walnut (CM-002)



white washed oak (CM-095)



textured black (CM-049)

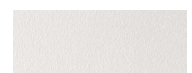

textured white (CM-060)



satin nickel (CM-124)



brushed brass (CM-120)



distressed brass (CM-117)

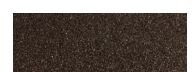

oil rubbed bronze (CM-029)

MATERIAL & FINISH OPTIONS

Rima part # 03-270-

Body

Wood Construction

- walnut (CM-001)
- dark stained walnut (CM-002)
- white washed oak (CM-095)

Metal Construction

- textured black (CM-049)
- textured white (CM-060)
- satin nickel (CM-124)
- brushed brass (CM-120)
- distressed brass (CM-117)
- oil rubbed bronze (CM-029)

Lamping

- 2700 K LED
- 3000 K LED
- 3500 K LED
- 4000 K LED

Driver

- AC Input Voltage Range: 120-277 V
- 120 V input: TRIAC, ELV & 0-10 V dimmable
- 240 & 277 V input: only 0-10 V dimmable

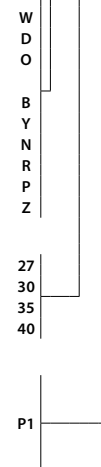

Includes: frosted polymer diffuser (CM-051)

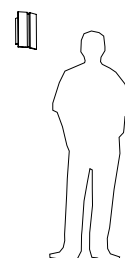

Via

sconce / ceiling flush mount

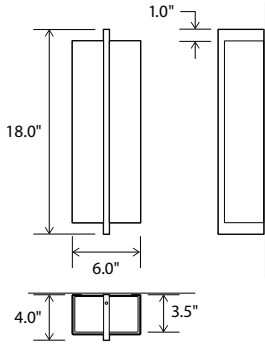

- Dimensions: 18" x 6" x 4"
- Materials: solid wood, polymer
- Product weight: 2 lb
- Integrated LED Specifications*
- Light output: 500 Lumens (source)
- Light color*: 2700 K or 3500 K
- Color accuracy: 90+ CRI
- Power usage: 7 W
- Dimmable (see driver below)
- Input voltage: 24 V DC (driver included)
- Driver location: must be housed in J-box
- Driver dimensions: 3" x 1.5" x 1"
- Mounting: ceiling or wall
- Candelabra Base Specifications*
- Lamping: 2x candelabra E12 base sockets, 10 W max each (bulbs not included)
- Select bulbs can achieve over 500 lumens each
- Input voltage: 120 V AC max
- Mounting: wall only



walnut



ceiling flush mount, dark stained walnut



white washed oak

The Via has an understated geometry with sophisticated detailing and proportion. The substantial glowing volume of the Via is punctuated by a thin plane of rich American walnut striking a balance and harmony.

Nick Sheridan,
Designer



walnut (CM-001)



dark stained walnut (CM-002)



white washed oak (CM-095)

MATERIAL & FINISH OPTIONS

Via part #: 03-190-

<i>Wood Body</i>		
walnut (CM-001)	W	
dark stained walnut (CM-002)	D	
white washed oak (CM-095)	O	
<i>Lamping</i>		
2700 K LED	27	
3500 K LED	35	
Candelabra base E12 socket	CB	
<i>Driver</i>		
120 V AC input voltage	P1	
TRIAC, ELV, or 0-10V dimmable		
277 V AC input voltage	P2	
TRIAC, ELV & 0-10 V dimming		

Includes: frosted polymer (CM-051)

Inquire about other input voltages

*Available in 3000K, 4000K and other color temperatures upon request

Emergency backup option available upon request

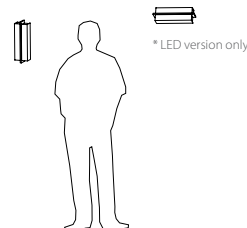



brushed brass, walnut

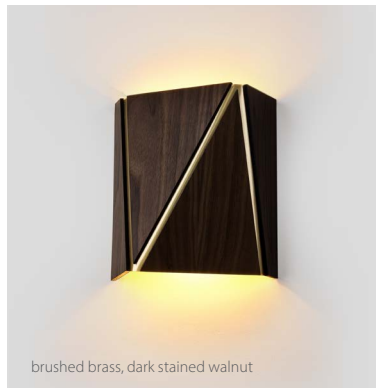

brushed brass, dark stained walnut

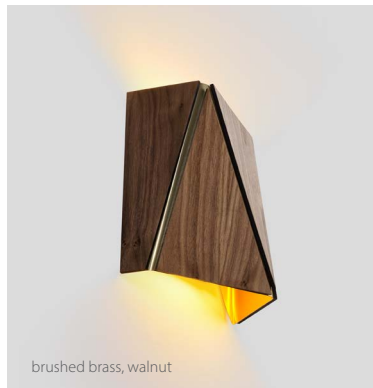

brushed brass, walnut

Inspired by the Calx pendant, the materials and method inform the design greatly. While the Calx sconce is clean and simple, it also offers a beautiful texture and subtle complexity to a wall.

Nick Sheridan,
Designer

Calx
sconce

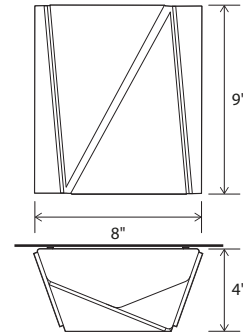

Dimensions: 8" x 9" x 4"
Materials: wood, metal
Product weight: 2 lb
Light source: integrated LED
Light output: 1130 Lumens (source)
Light color*: 2700 K or 3500 K
Color accuracy: 90+ CRI
Power usage: 13 W
Dimmable (see driver below)
Wood grain will vary
Specifications subject to change



MATERIAL & FINISH OPTIONS

Calx sconce part # 03-138-

Metal Finish

- brushed aluminum (CM-012)
- brushed rose gold (CM-046)
- brushed brass (CM-047)

Wood Finish

- walnut (CM-055)
- dark stained walnut (CM-056)

Lamping

- 2700 K LED
- 3500 K LED

Driver

- AC Input Voltage Range: 120-277 V
- 120 V input: TRIAC, ELV & 0-10 V dimmable
- 240 & 277 V input: only 0-10 V dimmable

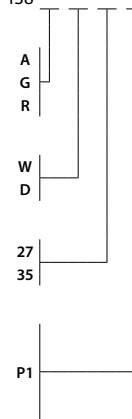

brushed aluminum (CM-012)



brushed rose gold (CM-046)



brushed brass (CM-047)



walnut (CM-055)



dark stained walnut (CM-056)

Calx pendant also available

*Available in 3000K, 4000K and other color temperatures upon request

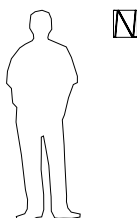



Spero
sconce



white / tan leather



black / black leather



brass / brown leather



distressed brass / black leather

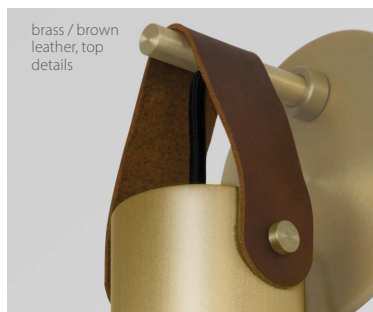

brass / brown leather, top details

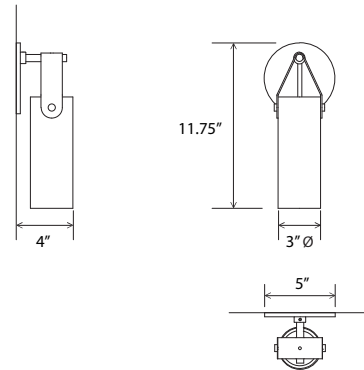

Dimensions: 5" x 11.75" x 4"
Product weight: 2 lb
Lamping: 1x E26 base, PAR20 lamp, 20 W max
Specifications subject to change



MATERIAL & FINISH OPTIONS

Spero sconce part # 03-260-

Standard Combinations

black / black leather	B
brass / brown leather	R
distressed brass / black leather	D
white / tan leather	W

Bulb Options

PAR20 LED bulb included - 2700 K, 90CRI, 40 degree flood	27
no bulb included	00



black

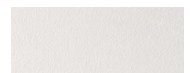

white

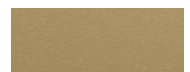

brass



distressed brass

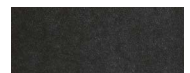

black leather

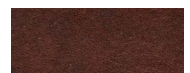

brown leather

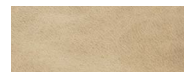

tan leather

The Spero Sconce illustrates a minimalist mindset without sacrificing design details that define the fixture. Pronounced metal accents join the leather strap to the shade, adding a balanced contrast between the different elements. The bottom aperture allows the delivery of ample light while shielding the rest of the space from glare.

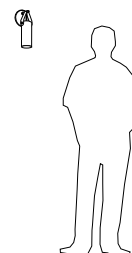

Penna 16 / 40 / 64
sconce

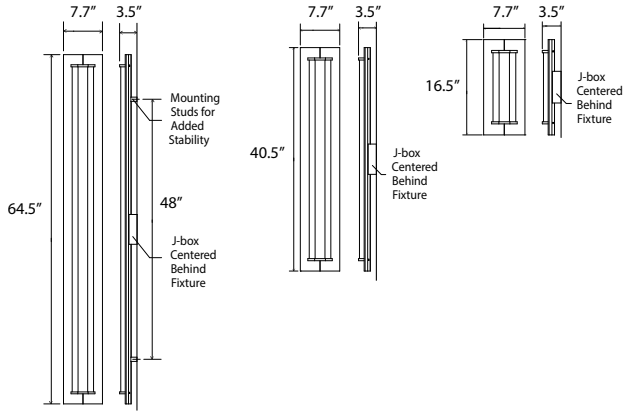

Penna 16 dimensions: 16.5" x 7.7" x 3.5"
 Penna 40 dimensions: 40.5" x 7.7" x 3.5"
 Penna 64 dimensions: 64.5" x 7.7" x 3.5"
 Penna 16 weight: 4 lb
 Penna 40 weight: 6 lb
 Penna 64 weight: 9 lb

Light source: integrated LED
 Penna 16 light output: 510 Lumens (source)
 Penna 40 light output: 1530 Lumens (source)
 Penna 64 light output: 2550 Lumens (source)
 Light color*: 2700 K or 3500 K
 Color accuracy: 90+ CRI
 Penna 16 power usage: 7 W
 Penna 40 power usage: 21 W
 Penna 64 power usage: 35 W
 Dimmable (see driver below)
 Wood grain will vary
 Specifications subject to change



MATERIAL & FINISH OPTIONS

Penna sconce part #: 03-220- B -

Size	16	40	64
Metal Finish	R	D	
Wood Body	W	D	O
Lamping	27	35	
Driver	P1	P2	

brushed brass (CM-120)
 distressed brass (CM-117)
 walnut (CM-001)
 dark stained walnut (CM-002)
 white washed oak (CM-095)
 2700 K LED
 3500 K LED
 120 V AC input voltage
 TRIAC, ELV, or 0-10V dimmable
 277 V AC input voltage
 TRIAC, ELV & 0-10 V dimming



brushed brass (CM-120)



distressed brass (CM-117)



walnut (CM-001)

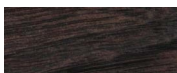

dark stained walnut (CM-002)



white washed oak (CM-095)

Includes: frosted polymer (CM-057)

*Available in 3000K, 4000K and other color temperatures upon request



Penna 16 walnut / Penna 40 dark stained walnut / Penna 64 walnut



walnut, brushed brass



white washed oak, brushed brass



Penna 64, mounting studs

On our Cerno journey, we continue to evolve as designers and craftsman. The Penna is a celebration of us drawing and reflecting on our last ten years. This design is an embodiment of all the lessons that we have learned from designing and building thousands of lights. This fixture balances utility and sophisticated beauty well. The walnut, brass, and leather work in concert to compose a modern form with materials that have been used for thousands of years.

Nick Sheridan,
Designer

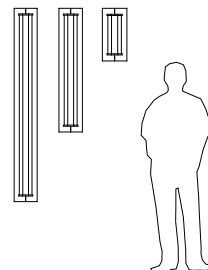

Vesper
sconce



dark stained walnut

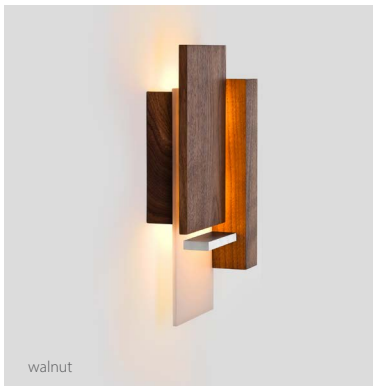

walnut

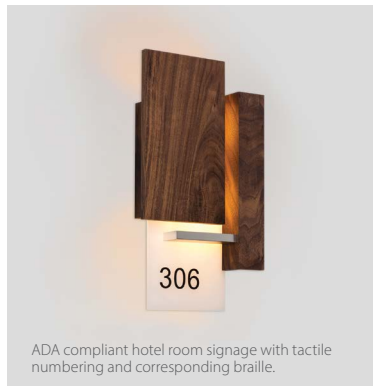

ADA compliant hotel room signage with tactile numbering and corresponding braille.

The Vesper is a very simple geometric sculpture composed of brushed aluminum, American black walnut, and white polymer. The light not only washes up and down the wall but also filters out through the composition, exhibiting the fixture's depth in three dimensions.

Nick Sheridan,
Designer

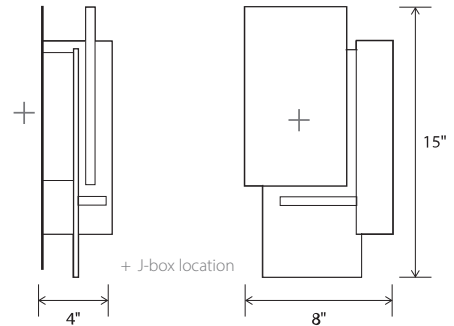
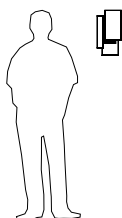

Dimensions: 15" x 8" x 4"
 Materials: solid wood, polymer, aluminum
 Product weight: 4 lb
 Light source: integrated LED
 Light output: 1130 Lumens (source)
 Light color*: 2700 K or 3500 K
 Color accuracy: 90+ CRI
 Power usage: 13 W
 Dimmable (see driver below)
 ADA compliant hotel room signage with tactile numbering and corresponding braille available
 Wood grain will vary
 Specifications subject to change



MATERIAL & FINISH OPTIONS

Vesper part # 03-132-		
Wood Body		
walnut (CM-001)	W	
dark stained walnut (CM-002)	D	
white washed oak (CM-095)	O	
Lamping		
2700 K LED	27	
3500 K LED	35	
Driver		
AC Input Voltage Range: 120-277 V		
120 V input: TRIAC, ELV & 0-10 V dimmable	P1	
240 & 277 V input: only 0-10 V dimmable		



brushed aluminum (CM-006)



walnut (CM-001)

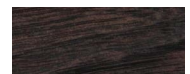

dark stained walnut (CM-002)



white washed oak (CM-095)

Includes:
 frosted polymer (CM-024)
 brushed aluminum (CM-006)

*Available in 3000K, 4000K and other color temperatures upon request



Tempus, white washed oak

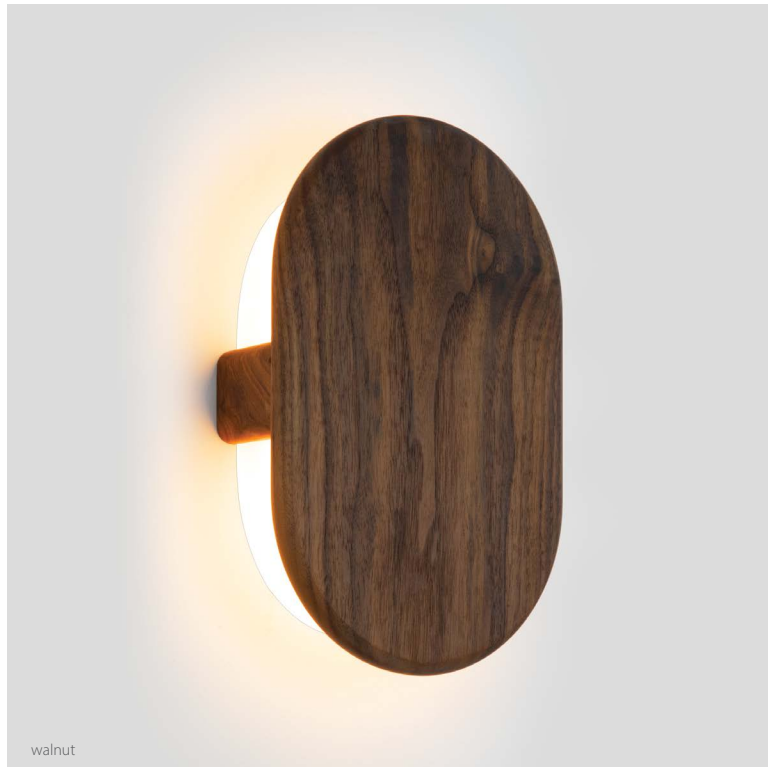

walnut

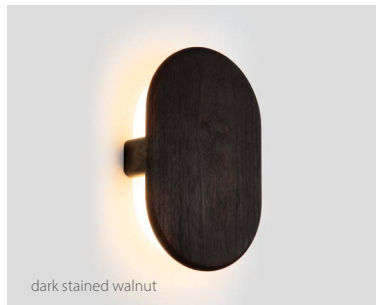

dark stained walnut



dark stained walnut



white washed oak



white washed oak

The Tempus Sconce draws inspiration from nature's beautiful designs. The rounded profile, rounded edges, and ample but smooth diffuse light exudes warmth. The solid wood body highlights the elegance of the wood grain. The design is dynamic, working well in traditional, transitional, or sleek modern environments.

Nick Sheridan,
Designer

Tempus sconce

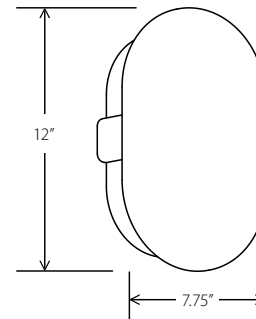

Dimensions: 12" x 7.75" x 3"
 Product weight: 2 lb
 Light source: integrated LED
 Light output: 1280 Lumens (source)
 Light Color: 2700 K, 3000 K, 3500 K, or 4000 K
 Color accuracy: 90+ CRI
 Power usage: 14 W
 Wood grain will vary
 Specifications subject to change



MATERIAL & FINISH OPTIONS

Tempus part # 03-280-

Wood Body

walnut (CM-001)
 dark stained walnut (CM-002)
 white washed oak (CM-095)

Lamping

2700 K LED
 3000 K LED
 3500 K LED
 4000 K LED

Driver

AC Input Voltage Range: 120-277 V
 120 V input: TRIAC, ELV & 0-10 V dimmable
 240 & 277 V input: only 0-10 V dimmable

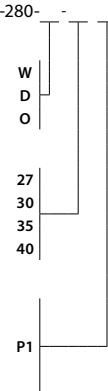

walnut (CM-001)

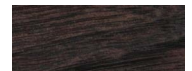

dark stained walnut (CM-002)



white washed oak (CM-095)

Includes: frosted polymer (CM-057)

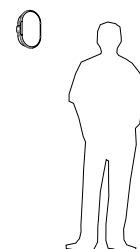

ACUO
sconce

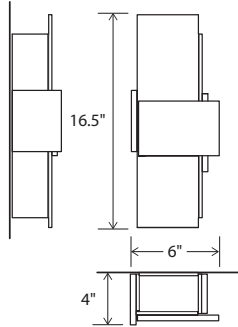

Dimensions: 16.5" x 6" x 4"
 Materials: solid wood, polymer, aluminum
 Product weight: 3 lb (CM-001/CM-002)
 5 lb (CM-006)

Integrated LED Specifications
 Light output: 1130 Lumens (source)
 Light color*: 2700 K or 3500 K
 Color accuracy: 90+ CRI
 Power usage: 14 W
 Dimmable (see driver below)

GU-24 Base Specifications
 Lamping: 2x GU-24 base sockets, 18 W max each
 Input voltage: 300 V AC max

ADA compliant hotel room signage with tactile numbering and corresponding braille available
 Wood grain will vary
 Specifications subject to change



MATERIAL & FINISH OPTIONS

Acuo part #: 03-130-

Wood Body	
walnut (CM-001)	W
dark stained walnut (CM-002)	D
white washed oak (CM-095)	O
brushed aluminum (CM-006)	A
Lamping	
2700 K LED	27
3500 K LED	35
GU-24 base socket	GU
Driver	
AC Input Voltage Range: 120-277 V	
120 V input: TRIAC, ELV & 0-10 V dimmable	P1
240 & 277 V input: only 0-10 V dimmable	



brushed aluminum (CM-006)



walnut (CM-001)



dark stained walnut (CM-002)



white washed oak (CM-095)



walnut



white washed oak



brushed aluminum

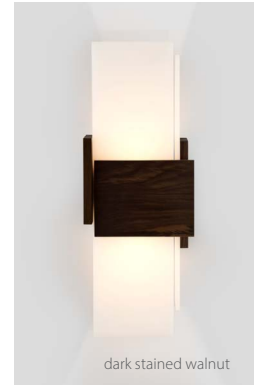

dark stained walnut

It's a 3 sided box, which has been carefully deconstructed to a sculptural state. The careful composition of overlap and void create interest and complexity to a very straightforward, well-functioning wall sconce. The tectonic disconnection in form allows you to witness the solid American black walnut's grain as it travels through each solid block.

Nick Sheridan,
Designer

Includes: frosted polymer (CM-024)
 Emergency backup option available upon request
 Requires oversized J-box
 J-box centered behind wood/aluminum body
 *Available in 3000K, 4000K and other color temperatures upon request





Capio S / L
sconce

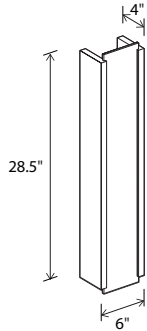
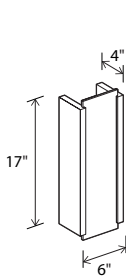

Dimensions: 17" x 6" x 4"
 Materials: solid wood, polymer
 Product weight: 4 lb
 Light source: integrated LED
 Light output: 500 Lumens (source)
 Light color*: 2700 K or 3500 K
 Color accuracy: 90+ CRI
 Power usage: 7 W
 Dimmable (see driver below)
 Input voltage: 24 V DC (driver included)
 Driver location: must be housed in J-box
 Driver dimensions: 2.6" x 1.3" x 0.8"
 ADA compliant hotel room signage with
 tactile numbering and corresponding
 braille available
 Wood grain will vary
 Specifications subject to change



Dimensions: 28.5" x 6" x 4"
 Materials: solid wood, polymer
 Product weight: 7 lb
 Light source: integrated LED
 Light output: 1000 Lumens (source)
 Light color*: 2700 K or 3500 K
 Color accuracy: 90+ CRI
 Power usage: 14 W
 Dimmable (see driver below)
 Input voltage: 24 V DC (driver included)
 Driver location: must be housed in J-box
 Driver dimensions: 3" x 1.5" x 1"
 ADA compliant hotel room signage with
 tactile numbering and corresponding
 braille available
 Wood grain will vary
 Specifications subject to change



MATERIAL & FINISH OPTIONS

Capio S part #: 03-180-S -

Wood Body		
walnut (CM-001)	W	
dark stained walnut (CM-002)	D	
maple (CM-005)	M	
white washed oak (CM-095)	O	
Lamping		
2700 K LED	27	
3500 K LED	35	
Driver		
120 V AC input voltage TRIAC, ELV & 0-10 V dimming	P1	
277 V AC input voltage TRIAC, ELV & 0-10 V dimming	P2	

MATERIAL & FINISH OPTIONS

Capio S part #: 03-180-L -

Wood Body		
walnut (CM-001)	W	
dark stained walnut (CM-002)	D	
maple (CM-005)	M	
white washed oak (CM-095)	O	
Lamping		
2700 K LED	27	
3500 K LED	35	
Driver		
120 V AC input voltage TRIAC, ELV & 0-10 V dimming	P1	
277 V AC input voltage TRIAC, ELV & 0-10 V dimming	P2	



walnut



white washed oak



walnut

The Capio is an exercise in restraint and efficiency consisting of just two solid wood sides that capture a single light diffusing lens. The clean and simple design allows for horizontal or vertical mounting as well as compelling compositions when used in multiples.

Nick Sheridan,
Designer

Includes: frosted polymer (CM-024)

*Available in 3000K, 4000K and other color temperatures upon request
 Emergency backup option available upon request, requires oversized J-box



walnut (CM-001)

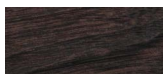

dark stained walnut (CM-002)



white washed oak (CM-095)



maple (CM-005)

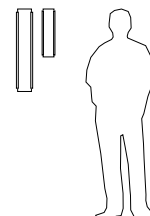

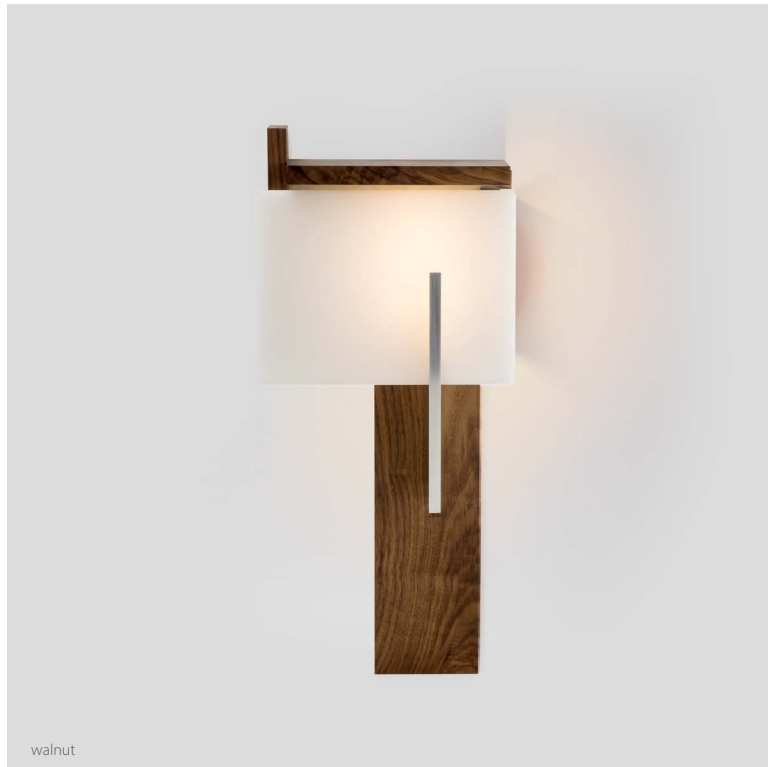

walnut



dark stained walnut



walnut

The Oris has a strong and commanding presence with its highly architectonic form. The thick solid stock walnut and solid aluminum central fin give the Oris a feeling of permanence and integration into the surrounding architecture. The simple asymmetrical composition adds an understated complexity, as well as excellent illumination, to any wall.

Nick Sheridan,
Designer

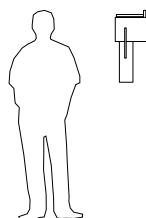

Oris sconce

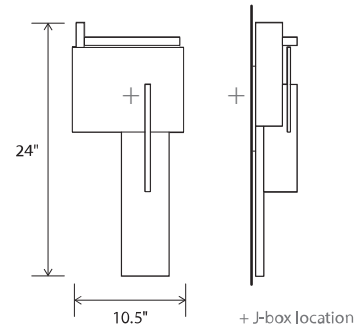

Dimensions: 24" x 10.5" x 4"
 Materials: solid wood, polymer, aluminum
 Product weight: 6 lb
 Light source: integrated LED
 Light output: 1130 Lumens (source)
 Light color*: 2700 K or 3500 K
 Color accuracy: 90+ CRI
 Power usage: 13 W
 Dimmable (see driver below)
 ADA compliant hotel room signage with tactile numbering and corresponding braille available
 Wood grain will vary
 Specifications subject to change



MATERIAL & FINISH OPTIONS

Oris part # 03-140-	
Metal Finish	
brushed aluminum (CM-006)	A
Wood Body	
walnut (CM-001)	W
dark stained walnut (CM-002)	D
Lamping	
2700 K LED	27
3500 K LED	35
Driver	
AC Input Voltage Range: 120-277 V	
120 V input: TRIAC, ELV & 0-10 V dimmable	P1
240 & 277 V input: only 0-10 V dimmable	



brushed aluminum (CM-006)



walnut (CM-001)

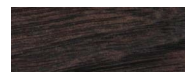

dark stained walnut (CM-002)

Includes: frosted polymer (CM-024)

*Available in 3000K, 4000K and other color temperatures upon request

Emergency backup option available upon request, requires oversized J-box



Ora
sconce

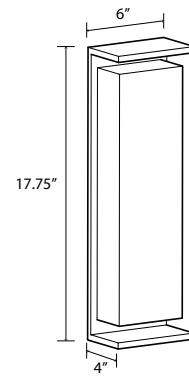

Dimensions: 17.75" x 6" x 4"
 Product weight: 5 lb (wood), 8 lb (metal)
 Light source: integrated LED
 Light output: 1124 Lumens (source)
 Light color: 2700 K, 3000 K, or 3500 K
 Color accuracy: 90+ CRI
 Power usage: 15.2 W
 Wood grain will vary
 Specifications subject to change



MATERIAL & FINISH OPTIONS

Ora part # 03-290-

Body - Wood Construction
 walnut (CM-001)
 dark stained walnut (CM-002)
 white washed oak (CM-095)

Body - Metal Construction
 textured black (CM-049)
 textured white (CM-060)
 brushed brass (CM-120)
 distressed brass (CM-117)
 brushed aluminum (CM-119)

Lamping
 2700 K LED
 3000 K LED
 3500 K LED

Driver
 100-305 V AC input voltage
 TRIAC, ELV & 0-10 V dimming

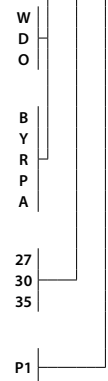

Includes: frosted polymer (CM-129)

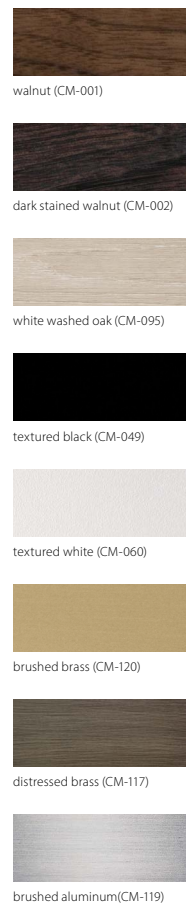
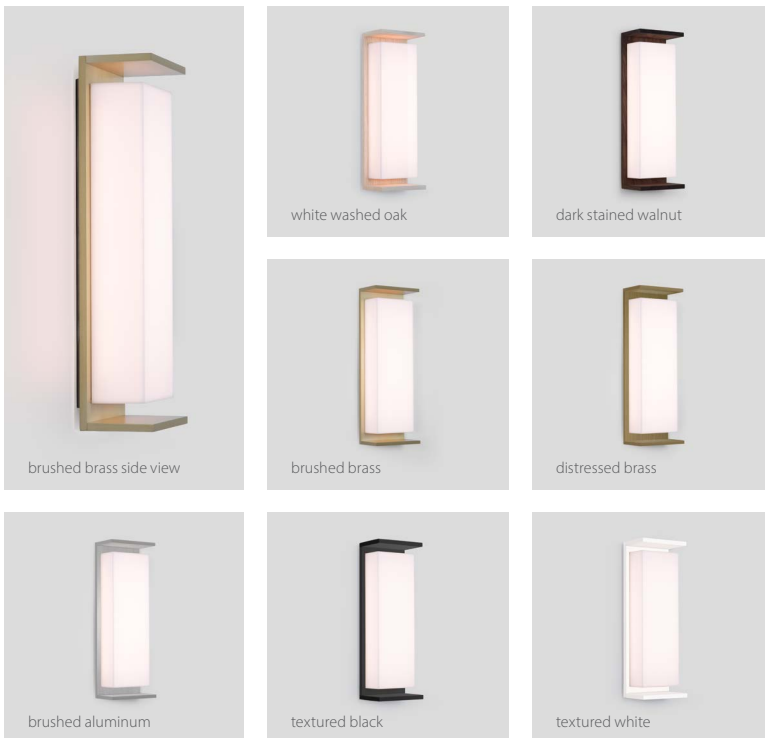

The Ora's sturdy design prioritized sleekness and structural integrity. This sconce is efficient and delivers ample usable light. A minimalist aesthetic makes it adaptable and suitable for different genres of designed environments. By simply selecting a natural hardwood or metal finish, a designer can completely change the feel of a room.

Nick Sheridan,
Designer

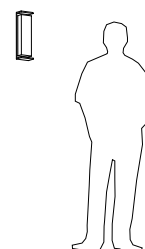





Tersus
sconce

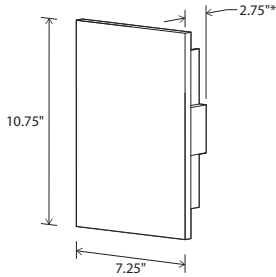

Dimensions: 10.75" x 7.25" x 2.75"
 Materials: solid wood, polymer,
 metal option, stone option
 Product weight: 2 lb (5 lb marble)
 Light source: integrated LED
 Light output: 1130 Lumens (source)
 Light color*: 2700 K or 3500 K
 Color accuracy: 90+ CRI
 Power usage: 13 W
 Dimmable (see driver below)
 Wood grain and stone will vary
 Specifications subject to change



walnut (CM-001)



dark stained walnut (CM-002)



maple (CM-005)



white washed oak (CM-095)



brushed aluminum (CM-012)



brushed rose gold (CM-046)



brushed brass (CM-047)



carrara marble (CM-078)

MATERIAL & FINISH OPTIONS

Tersus part #: 03-136-

Wood Body	
walnut (CM-001)	W
dark stained walnut (CM-002)	D
maple (CM-005)	M
white washed oak (CM-095)	O
Optional Face Material	
brushed aluminum (CM-012)	A
brushed rose gold (CM-046)	R
brushed brass (CM-047)	B
carrara marble (CM-078)	C
none (leave blank)	
Lamping	
2700 K LED	27
3500 K LED	35
Driver	
AC Input Voltage Range: 120-277 V	
120 V input: TRIAC, ELV & 0-10 V dimmable	P1
240 & 277 V input: only 0-10 V dimmable	

Includes: frosted polymer (CM-024)

J-box centered behind fixture

*Available in 3000K, 4000K and other color temperatures upon request



walnut, carrara marble



white washed oak



walnut



dark stained walnut, brushed brass



dark stained walnut



walnut, brushed rose gold



maple, brushed aluminum



maple

The Tersus is an example of the simplest form unlocking a myriad of design possibilities. The long reaching light pattern cast on the wall coupled with the numerous finishes and materials offered makes the Tersus well versed for all kinds of compositions and applications.

Nick Sheridan,
Designer

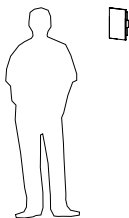

Sedo
sconce

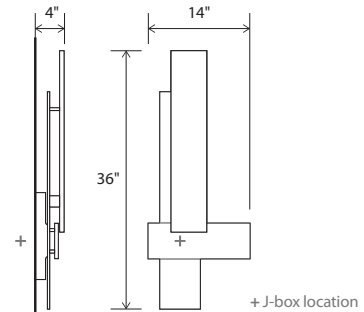

Dimensions: 36" x 14" x 4"
 Materials: solid wood, polymer
 Product weight: 6 lb
 Light source: integrated LED
 Light output: 1130 Lumens (source)
 Light color*: 2700 K or 3500 K
 Color accuracy: 90+ CRI
 Power usage: 13 W
 Dimmable (see driver below)
 ADA compliant hotel room signage with tactile numbering and corresponding braille available
 Wood grain will vary
 Specifications subject to change



MATERIAL & FINISH OPTIONS

Sedo part # 03-133-

Wood Body	
walnut (CM-001)	W
dark stained walnut (CM-002)	D
Lamping	
2700 K LED	27
3500 K LED	35
Driver	
AC Input Voltage Range: 120-277 V	
120 V input: TRIAC, ELV & 0-10 V dimmable	P1
240 & 277 V input: only 0-10 V dimmable	



Includes: frosted polymer (CM-024)

*Available in 3000K, 4000K and other color temperatures upon request

Emergency backup option available upon request, requires oversized J-box

The Sedo is composed of just three floating planes all kept parallel to the wall. This simple composition cloaks the light engine from view and filters the light as it is delivered far up and down the wall. It's this wall grazing and diffuser glow that gives the Sedo a strong architectural presence.

Nick Sheridan,
Designer

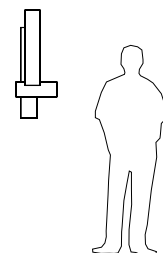





brushed brass



brushed aluminum



distressed brass



oiled bronze

The Ansa is a simple form that has been detailed and executed without compromise. The robust metal collar broadly trains the light while the light diffusing blades closely attenuate the wash pattern on the wall, yielding a simple and sophisticated feel.

Nick Sheridan,
Designer

Ansa
sconce

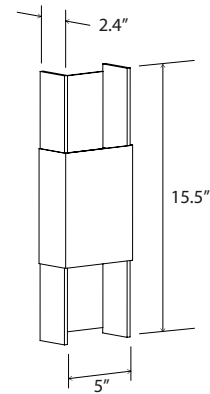

Dimensions: 15.5" x 5" x 2.4"
 Materials: metal, polymer
 Product weight: 3 lb
 Light source: integrated LED
 Light output: 1130 Lumens (source)
 Light color*: 2700 K or 3500 K
 Color accuracy: 90+ CRI
 Power usage: 13 W
 Dimmable (see driver below)
 Specifications subject to change



MATERIAL & FINISH OPTIONS

Ansa part # 03-137-

Metal Finish

- brushed aluminum (CM-006)
- brushed brass (CM-008)
- distressed brass (CM-009)
- oiled bronze (CM-010)

Lamping

- 2700 K LED
- 3500 K LED

Driver

- AC Input Voltage Range: 120-277 V
- 120 V input: TRIAC, ELV & 0-10 V dimmable
- 240 & 277 V input: only 0-10 V dimmable

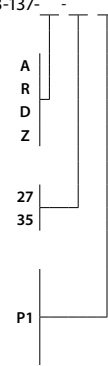

brushed aluminum (CM-006)



brushed brass (CM-008)



distressed brass (CM-009)



oiled bronze (CM-010)

Includes: frosted polymer (CM-024)

J-box centered behind fixture

*Available in 3000K, 4000K and other color temperatures upon request

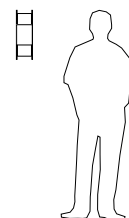

Fortis
 sconce

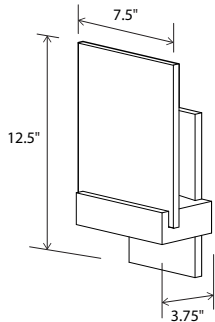

Dimensions: 12.5" x 7.5" x 3.75"
 Materials: solid wood, metal, marble option
 Product weight: 10 lb
 Light source: integrated LED
 Light output: 565 Lumens (source)
 Light color*: 2700 K or 3500 K
 Color accuracy: 90+ CRI
 Power usage: 7 W
 Dimmable (see driver below)
 Wood grain and stone will vary
 Specifications subject to change



dark stained walnut, carrara marble



brushed brass (CM-120)



distressed brass (CM-117)



oiled bronze (CM-123)



brushed aluminum (CM-006)



walnut (CM-001)



dark stained walnut (CM-002)



carrara marble (CM-078)

MATERIAL & FINISH OPTIONS

Fortis part #: 03-170

Metal Finish				
brushed brass (CM-120)	R			
distressed brass (CM-117)	D			
oiled bronze (CM-123)	Z			
brushed aluminum (CM-006)	A			
Wood Finish				
walnut (CM-001)	W			
dark stained walnut (CM-002)	D			
Diffuser				
carrara marble (CM-078)	C			
Lamping				
2700 K LED	27			
3500 K LED	35			
Driver				
120 V AC input voltage TRIAC & ELV dimming	P1			
277 V AC input voltage 0-10V dimming	P2			

J-box centered behind metal plate

*Available in 3000K, 4000K and other color temperatures upon request

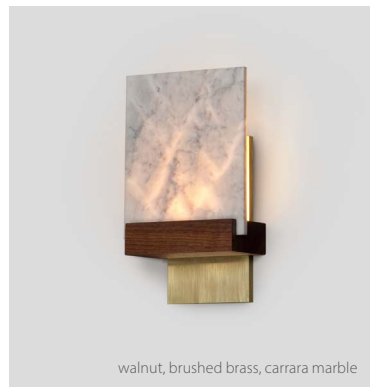
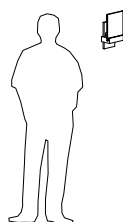

walnut, brushed brass, carrara marble



walnut, brushed aluminum, carrara marble

The Fortis wall sconce is a great example of the collaborative design process. The initial concept from the New York based Desiron was refined over many iterations. We then worked with the local Southern California artisan glass company Siemon & Salazar to achieve a very specific bubbled glass lens that diffuses the light. It is a strong and sophisticated display of three elements: a piece of metal, a piece of wood, and a piece of glass all beautifully showcased in light.

Nick Sheridan,
 Co-Designer

Clauco

sconce

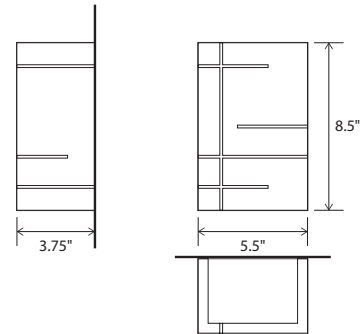

Dimensions: 8.5" x 5.5" x 3.75"
 Materials: solid wood, polymer
 Product weight: 4 lb
 Light source: integrated LED
 Light output: 1130 Lumens (source)
 Light color*: 2700 K or 3500 K
 Color accuracy: 90+ CRI
 Power usage: 13 W
 Dimmable (see driver below)
 Wood grain will vary
 Specifications subject to change



MATERIAL & FINISH OPTIONS

Clauco sconce part #: 03-150

Wood Body	
walnut (CM-001)	W
dark stained walnut (CM-002)	D
Lamping	
2700 K LED	27
3500 K LED	35
Driver	
AC Input Voltage Range: 120-277 V	
120 V input: TRIAC, ELV & 0-10 V dimmable	P1
240 & 277 V input: only 0-10 V dimmable	



walnut (CM-001)



dark stained walnut (CM-002)

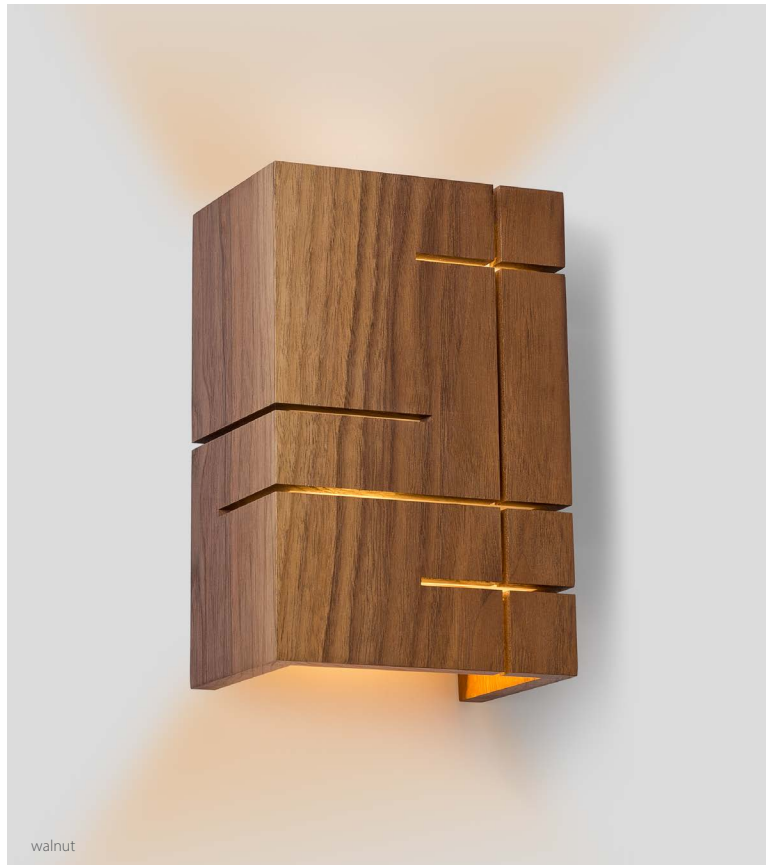

walnut



dark stained walnut



walnut

Includes: frosted polymer (CM-024)

J-box centered behind fixture

Also available in pendant version

*Available in 3000K, 4000K and other color temperatures upon request

The Clauco sconce showcases the beautiful natural walnut wood grain and sets it against the rigorous slits cut in each face as they wrap around the simple, clean shade form. A beautiful glow emanates from each slit, showing the striking rectilinear composition, in which all three sides are unique.

Nick Sheridan,
 Designer

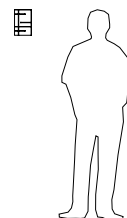



RIVER OVERLOOK
Gros ventre River Ranch
Jason Rich
JULY 2011 FALL ARTS FESTIVAL

Libri, walnut mounting kit, left model



right model, brushed aluminum, direct mount

Libri

bedside sconce reading light

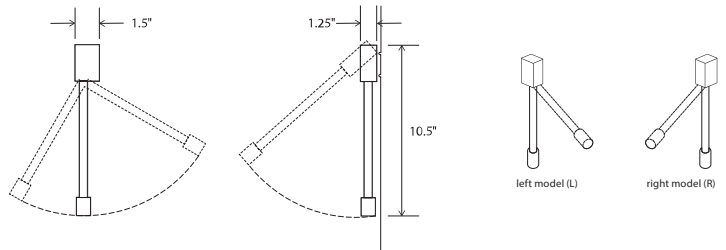

Dimensions: 10.5" x 1.5" x 1.2"
 Materials: aluminum, polymer, optional solid wood mounting
 Product weight: 1 lb
 Light source: integrated LED
 Light output: 160 Lumens (source)
 Light color: 2700 K
 Color accuracy: 90+ CRI
 Power usage: 2 W
 Automatic ON/OFF when arm is pulled away from wall
 Hardwired and corded versions available
 Hardwired model includes an external power supply (2.75" x 1.63" x 1.13")
 Requires space in J-box for included power adapter
 Alternate voltage/plug styles available
 Specifications subject to change

MATERIAL & FINISH OPTIONS

Libri part # 03-160-

Direction	
left model	L
right model	R
Finish	
brushed aluminum (CM-006)	A
white (CM-060)	Y
Installation	
corded (plug-in)	C
hardwired*	H

Alternate voltage / plug styles available

J-box centered behind fixture

*Hardwired installation requires room in the J-box for the included external power adapter (2" x 1" x 1.25"). Typically mounting kit is used. See mounting options below.



right model, white, mounting kit (3)

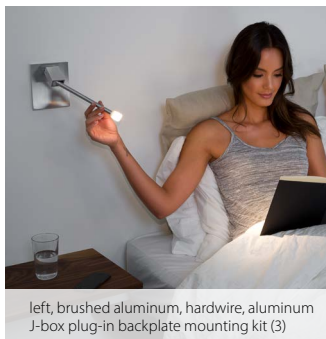

left, brushed aluminum, hardwire, aluminum J-box plug-in backplate mounting kit (3)



Mounting kits are sold separately. No Mounting Kit is required if Libri is to be installed by direct mount, which mounted directly to a headboard.

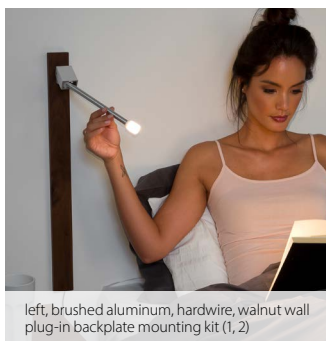

left, brushed aluminum, hardwire, walnut wall plug-in backplate mounting kit (1, 2)

Libri Mounting Kit

sconce backplate

J-box Backplate: Mounting Kit (3)
 J-box backplate is typically used when mounting to a J-box. Hardwired installation requires room in the J-box for the included external power adapter (2"x1" x 1.25").

Wall Mount Plug-in Backplate: Mounting Kit (1, 2)

Wall mount plug-in backplate is used when mounting directly to the wall and plugging into a wall outlet. The wall mount is an elongated rectangle that allows the cord to exit discreetly below the fixture.

MOUNTING KIT OPTIONS

Libri part # 03-160-10

Direction	
wall mount plug-in, left	1
wall mount plug-in, right	2
J-box backplate	3
Finish	
brushed aluminum (CM-006)	A
walnut (CM-001)	W
white (CM-060)	Y

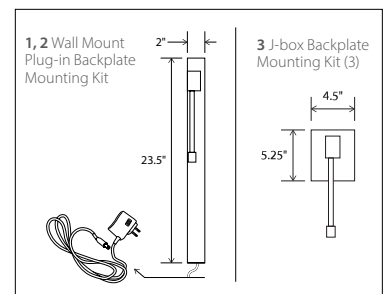

brushed aluminum(CM-006)



walnut (CM-001)

The Libri is about function and ease: an extremely articulate directional task light in a discrete and sturdy form that is very intuitive to use.

Nick Sheridan,
 Designer



Levo, walnut, left model



Levo

bedside wall sconce/reading lamp with USB charger

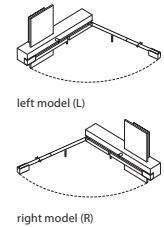
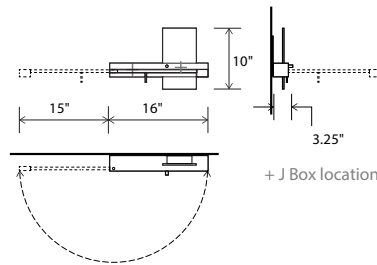

Dimensions: 10" x 16" x 3.25"
 Materials: solid wood, aluminum, polymer
 Product weight: 3 lb
 Light source: 2x integrated LED
 Static sconce light + swing arm w/ rotating head light
 Light output of static sconce source: 565 Lumens (source)
 Light output of swing arm source: 160 Lumens (source)
 Light color: 2700 K
 Color accuracy: 90+ CRI
 Power usage: 20 W total (10 W USB charger)
 USB charge current: 2 A
 Fully dimmable static sconce light with automatic ON/OFF swing arm light source
 Swing arm light is not dimmable
 Input voltage: 12 V DC (adapter included)
 Hardwired and corded versions available
 Hardwired model includes an external power supply (2.75" x 1.63" x 1.13")
 Requires space in J-box for included power adapter
 Alternate voltage/plug styles available

Hardwired adapter input voltage: 120-277 V AC
 Corded adapter input voltage: 120-240 V AC
 Wood grain will vary
 Specifications subject to change



MATERIAL & FINISH OPTIONS

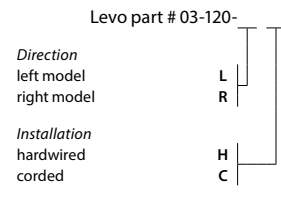

Includes:
 solid walnut body (CM-001)
 brushed aluminum (CM-006)
 frosted polymer (CM-024)

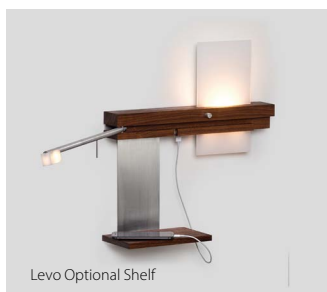

Levo Shelf Option

The introduction of the optional shelf for the Levo increases the utility of this fixture without compromising any aspect of the design. The shelf provides a perfect place to rest your phone or tablet while charging it. It is important to note that shelf is purchased separately from the Levo and can be retrofitted on existing Levos.

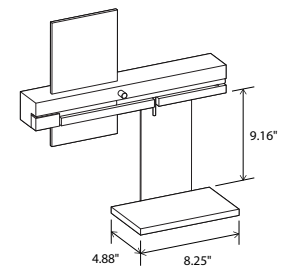

left model with shelf option

LEVO SHELF OPTIONS

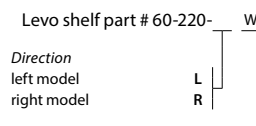

Includes:
 solid walnut shelf (CM-001)
 brushed aluminum (CM-006)

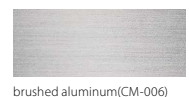

The goal for the Levo was to create a bedside wall fixture with great task lighting articulation that was intuitive enough to be used without prior knowledge of the fixture: all the while making it slender, sexy, and very robust.

Nick Sheridan,
 Designer



Forma table, black anodized aluminum, dark stained walnut, black amaretto



Table Lamps

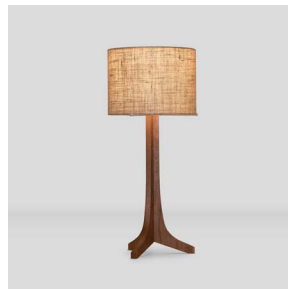

Nauta



Forma



Nauta table, brushed brass, walnut, burlap

Nauta
desk/table lamp

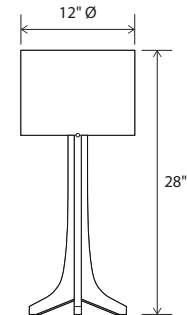

Dimensions: 12" Ø, 28"
 Materials: solid wood, aluminum, fabric shade
 Product weight: 3 lb
 Light source: medium base E26 socket
 Lamping: E26 base, 60 W max
 Input voltage: 250 V AC max
 Includes 8' clear silver cord with white plug
 On/Off rocker switch on socket
 Wood grain will vary
 Specifications subject to change



brushed aluminum, walnut, white linen

MATERIAL & FINISH OPTIONS

Nauta table part # 02-160-

<i>Metal Finish</i>	
brushed aluminum (CM-006)	A
brushed brass (CM-120)	R
<i>Wood Body</i>	
walnut (CM-001)	W
dark stained walnut (CM-002)	D
white washed oak (CM-095)	O
<i>Fabric Shade</i>	
black amaretto (CM-018)	A
white linen (CM-016)	L
burlap (CM-017)	N

Brass shade support arms feature wood plug in end of arm



brushed brass, white washed oak, black amaretto



brushed brass, dark stained walnut, burlap



details



brushed aluminum (CM-006)



brushed brass (CM-120)



walnut (CM-001)

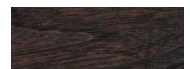

dark stained walnut (CM-002)



white washed oak (CM-095)



black amaretto (CM-018)



white linen (CM-016)



burlap (CM-017)

Efficiency and simplicity guided the design process for the Nauta table lamp. We designed the Forma several years ago with Frank Carfaro of Desiron, which profoundly influenced the Nauta's form. Our goal was to distill the Forma design without compromising it. The Nauta is clean, modern, and priced competitively.

Nick Sheridan,
Designer

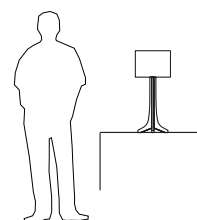

Forma
desk/table lamp

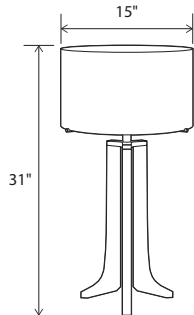

Dimensions: 15" Ø shade, 31" H
 Materials: solid wood, aluminum, fabric shade
 Product weight: 10 lb
 Light source: medium base E26 socket
 Lamping: E26 base, type A lamp, 60 W max
 Input voltage: 120 V AC max
 Dimmable on fixture
 Wood grain will vary
 Specifications subject to change



MATERIAL & FINISH OPTIONS

Forma table part # 02-150-

Metal Finish

- brushed aluminum (CM-006) A
- black anodized aluminum (CM-007) B

Wood Body

- walnut (CM-001) W
- dark stained walnut (CM-002) D

Fabric Shade

- black amaretto (CM-018) A
- white linen (CM-016) L
- burlap (CM-017) N

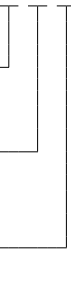

Alternate voltage / plug styles available



brushed aluminum, walnut, burlap



brushed aluminum (CM-006)



black anodized aluminum (CM-007)



walnut (CM-001)

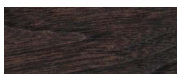

dark stained walnut (CM-002)



black amaretto (CM-018)



white linen (CM-016)

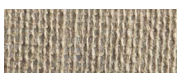

burlap (CM-017)

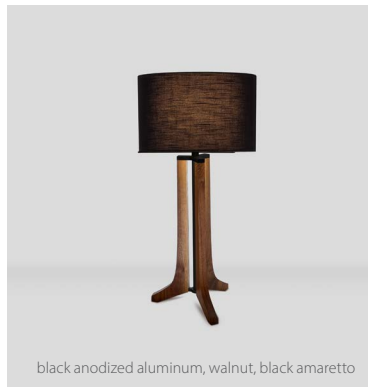

black anodized aluminum, walnut, black amaretto



brushed aluminum, dark stained walnut, white linen

Being our most traditional fixture, Frank Carfaro and I worked to design a piece that embraced both Cerno and Desiron's aesthetic, without deviating too much from either brand's design language. I am really pleased with the fluidity, posture and scale we achieved with the Forma table, and its likeness to the Forma floor lamp.

*Nick Sheridan,
Designer*

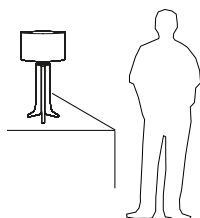



Forma table, brushed aluminum, walnut, burlap



Revelite AL
art light

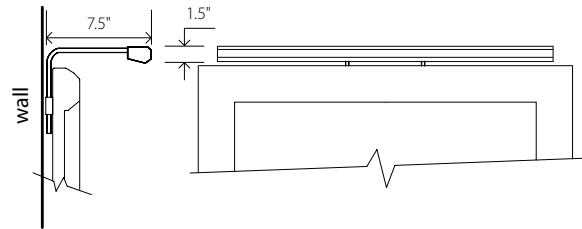

The Revelite AL brings art to life.

A challenge resolved by a slim luminaire that discreetly and evenly illuminates an artwork surface with beautiful color rendering accuracy.

CUSTOMIZED

Each AL is custom built and factory calibrated for an artwork's specific dimensions, distributing even illumination across the full width and height of the surface.

HIGH COLOR ACCURACY

To accurately reflect the artist's vision, the LED light source was designed to provide full color spectrum lighting with a color rendering index over 90 and an R9 value of 83.

ART SAFE

Revelite AL's LED technology provides a much safer alternative to legacy sources that emit excessive and damaging UV and heat.

LOW PROFILE

The minimal form virtually disappears against the frame or wall and pairs well with various styles of art, including contemporary, photographs behind glass and more traditional works.

US Patent # 7,070,293 and 9,134,004.

Other US and International Patents Pending.

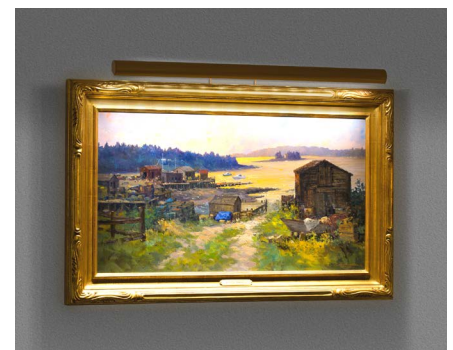

"These lights revealed subtleties in paintings you just don't see with ordinary lights. I think we are seeing, truly for the first time, what the artist really wanted us to see".

Pat Trenton, Ph.D.

Art expert, curator and writer

Visit revelite.com for detailed specifications and options.

Motus Swing Arm Bracket

accessory

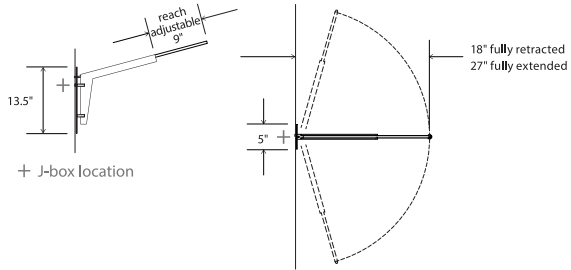

Dimensions: 18.38" x 5" x 26.8"
 Materials: solid wood, metal
 Product weight: 3 lb
 Max suspension weight: 5 lb
 Swing arm length can be adjusted from 18" to 27"
 Max drop length from tip of extended arm to top of pendant is 36"
 Swing arm rotation has adjustable resistance in pivot hinge
 Wood grain will vary
 Specifications subject to change

MATERIAL & FINISH OPTIONS

Motus part # 06-210-

Metal Finish

brushed aluminum (CM-006) **A**
 texture black powder coat (CM-049) **B**

Wood Body

walnut (CM-001) **W**
 dark stained walnut (CM-002) **D**

Patent # USD84618051



brushed aluminum (CM-006)



textured black powder coat (CM-049)



walnut (CM-001)

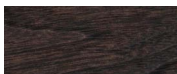

dark stained walnut (CM-002)



textured black powder coat, walnut,



Motus with Plura 18 Pendant
 Pendant dimensions: 18" Ø, 6.4"
 Lamping: 2x GU-24 base socket, 18 W max each
 See Plura 18 pendant for more information.

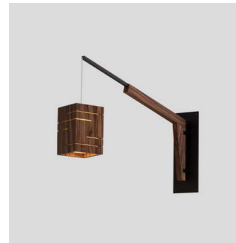

Motus with Claudio Pendant
 Pendant dimensions: 5" x 5", 7.25"
 Light source: integrated LED
 See Claudio accent pendant for more information.

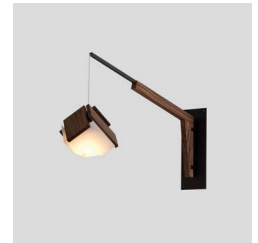

Motus with Mica Pendant
 Pendant dimensions: 9" Ø, 5.75"
 Light source: integrated LED
 See Mica accent pendant for more information.

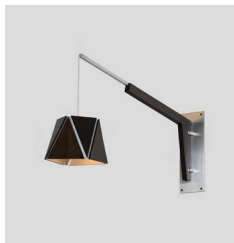

Motus with Calx 10 Pendant
 Pendant dimensions: 6.75" x 6.75", 6.4"
 Light source: integrated LED
 See Calx 10 accent pendant for more information.

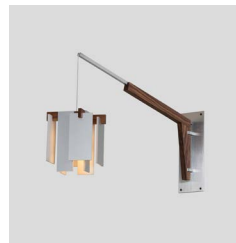

Motus with Salix Pendant
 Pendant dimensions: 7.5" x 7.5", 9.0"
 Light source: integrated LED
 See Salix accent pendant for more information.

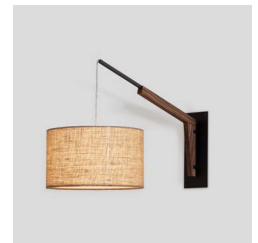

Motus with Talea Pendant
 The Talea is a stand alone fixture that also utilizes our swing arm bracket. Shade dimensions: 15" Ø, 9.0"
 Lamping: medium base E26 socket, type A lamp, 60 W max.

For additional finishes and full specifications see Talea, articulate wall sconce on page 93.

HOW IT WORKS: BUILD YOUR OWN FIXTURE

Pick one of the pendants shown at right and pair it with the Motus Swing Arm Bracket for a unique and versatile light fixture. To order, you will need to select a SKU for the pendant that you choose and a SKU for the Motus Swing Arm Bracket. The SKU builder for the Motus Swing Arm Bracket is above, and the SKU builders for the pendants are located on their respective tear sheets.



Motus in brushed aluminum and dark stained walnut, with Calx 10 in dark stained walnut

Canopy Accessories



Multi-Point Round Canopy
For 3 accent pendants
Dimensions: 12"Ø, 1.25" H



Multi-Point Linear Canopy
For linear pendants or 2 or 3 accent pendants
Dimensions: 20.6" x 4.6", 1.7" H

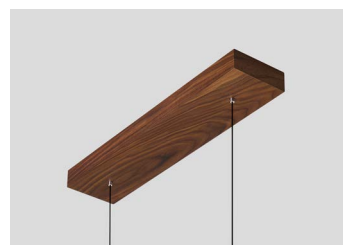

Wood Canopy Cover - walnut
Fits over linear canopies except for Camur canopy
Dimensions: 21.3" x 5.2", 2" H



Wood Canopy Cover - dark stained walnut
Fits over linear canopies except for Camur canopy
Dimensions: 21.3" x 5.2", 2" H

Finishes & Material Options

METAL

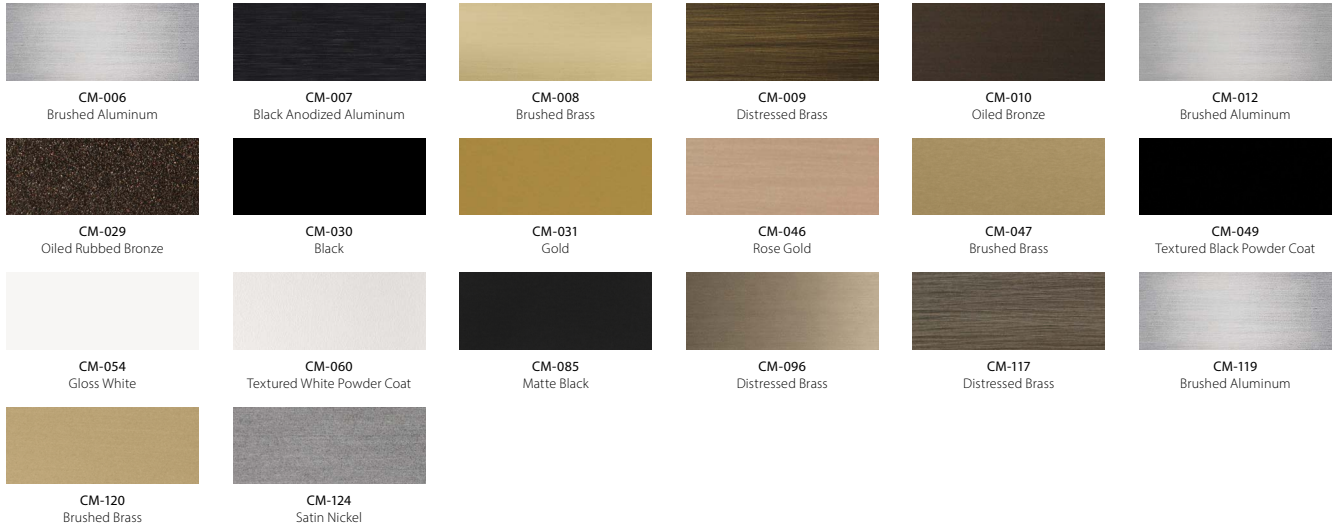

OUTDOOR

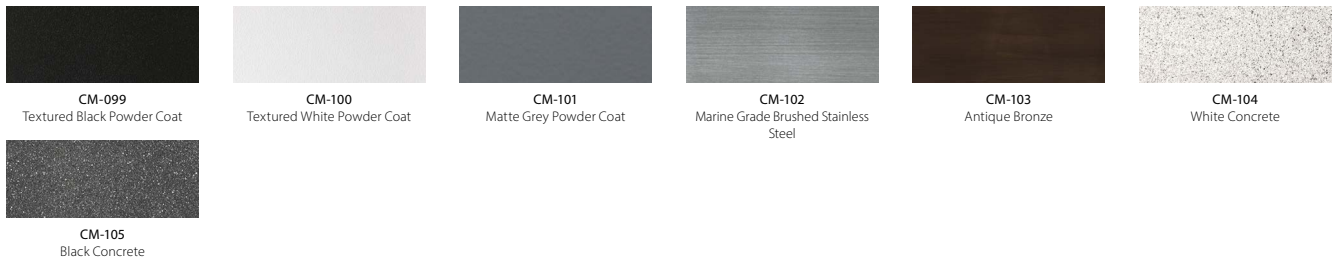

WOOD

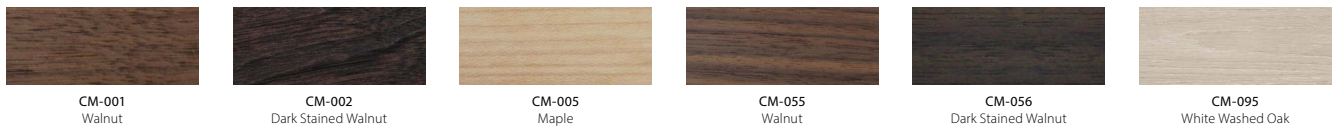

POLYMER



LEATHER



FABRIC SHADE



STONE



COLOR TEMPERATURES



2700 K



3000 K



3500 K



4000 K



cerno®

22892 GLENWOOD DRIVE, ALISO VIEJO, CA 92656 | 949.715.1534 | CERNOGROUP.COM