

USA & CANADA

Outdoor

VIBIA



VIBIA

Outdoor  
New Collections



# Outdoor

Bamboo  
8

Break  
16

Empty  
30

Meridiano  
44

Micro  
24

Origami  
4

Palo  
Alto  
36

Plis  
Outdoor  
28

Plus  
22

Scotch  
26

Wind  
12

# Origami

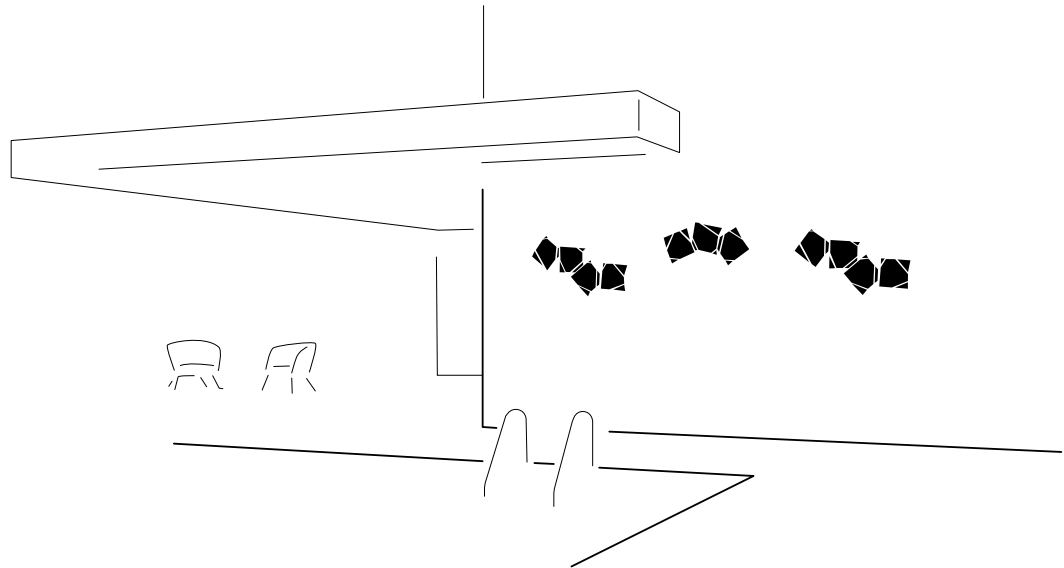
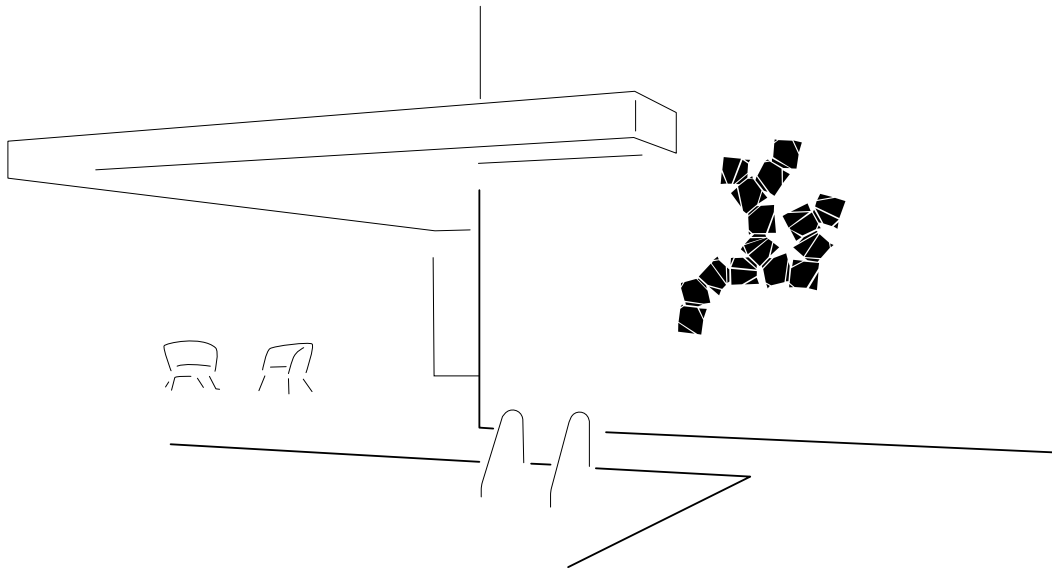

Design by Ramón Esteve.

Recalling the folded paper of the Japanese art form for which it's named, Origami generates a stunning play of light and shadows. Composed of two architectural modules that be arranged in countless personalized designs, it creates the effect of climbing ivy along a blank expanse of wall.



Recalling the folded paper of the Japanese art form for which it's named, Origami is composed of two architectural modules that be arranged in countless personalized designs. Positioning clusters across a broad surface creates the effect of climbing ivy along a blank expanse of wall and doubles as dramatic wall art. Powered by an LED and requiring only a single electrical outlet, Origami casts an ambient glow, generating a stunning play of light and shadows.

- 10 White (NCS S 0300-N)
- 29 Brown D1 (NCS S 8005-Y50R)
- 38 Terra Dark (NCS S 5040-Y70R)
- 53 Green M1 (NCS S 6005-G80Y)

Shade: ABS.  
Diffuser: Polycarbonate.

LED 2700K. 6.3W. 460 lm.  
Driver included 120V.  
Dimming: TRIAC.

A maximum of 30 modules can be connected to a single connection point.



#### Personalization options available

- Configuration layout at [vibia.com](http://vibia.com)
  - LED 3500 K
- Request more information,  
[sales@vibia.com](mailto:sales@vibia.com)

4500

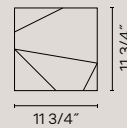

4501

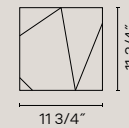

4504

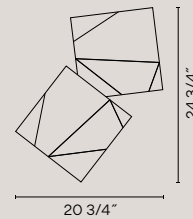

4506

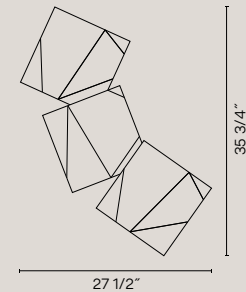

4508

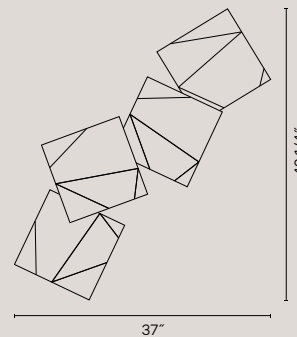



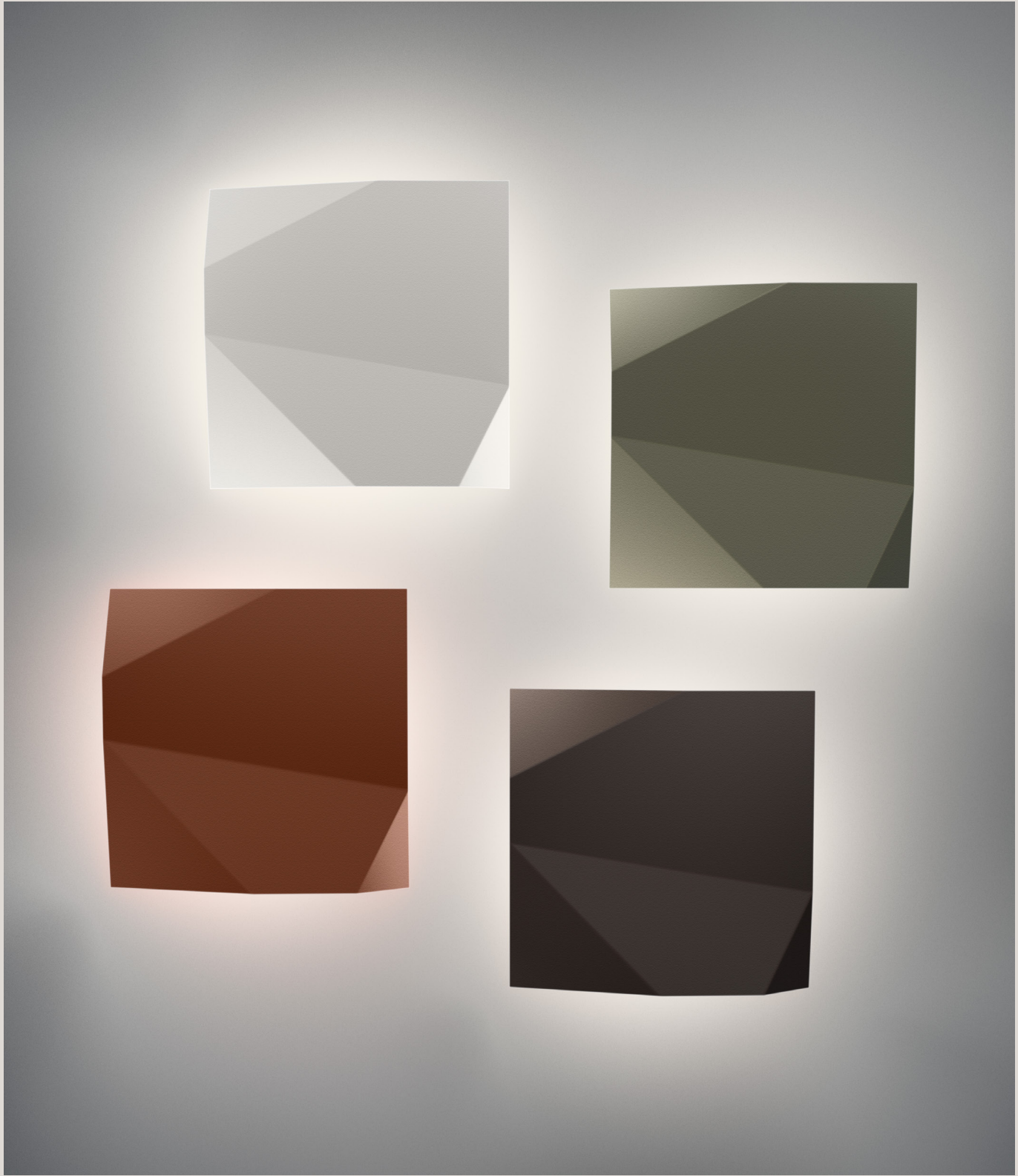

# Bamboo

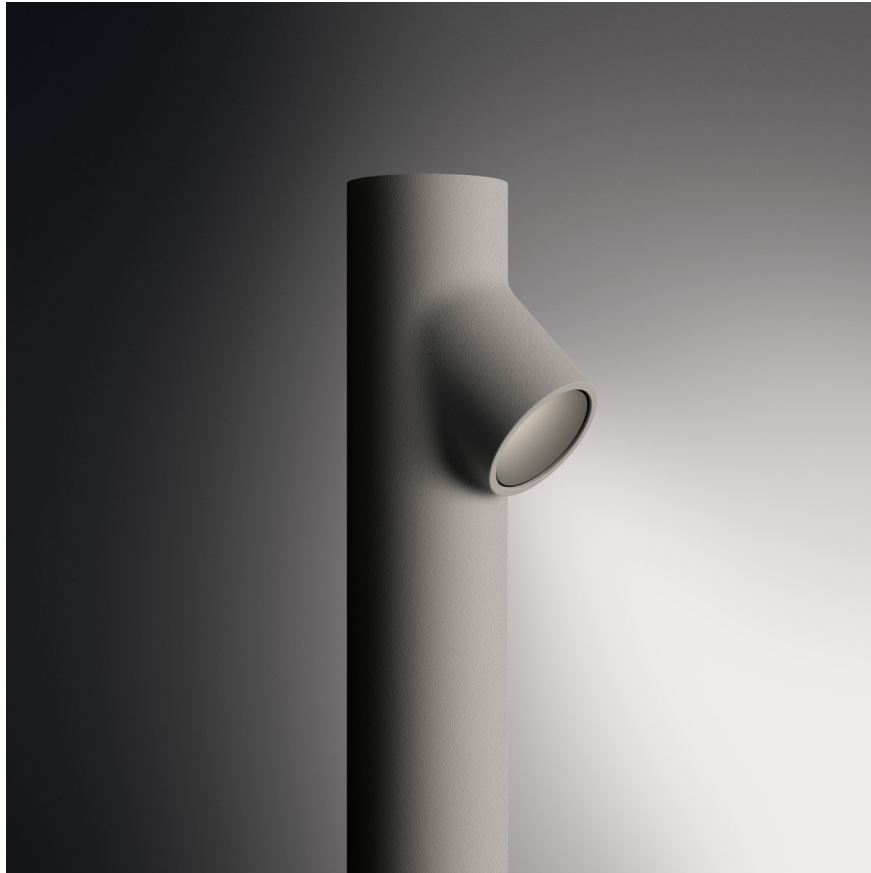

Design by Antoni Arola & Enric Rodríguez.

Bamboo's lean, natural form perfectly lends itself to an outdoor setting. Studded with LEDs, it seamlessly integrates with the landscape while adding a wash of light to walkways and common spaces.



Recalling the appearance of its namesake plant, Bamboo features a slender silhouette studded with LEDs along its lean frame. The natural form perfectly lends itself to an outdoor setting, seamlessly integrating with the landscape while adding a wash of light to walkways and common spaces. Bamboo is offered in one, two, or three pieces and is available in various heights.

● 07 Beige Green (RAL 7006)

● 54 Oxide (RAL 8017)

Body: Resin / glass fiber.

Diffuser: Methacrylate.

LED 2700 K. CRI >80.

Driver included 120V compatible.

Ground recessed version or surface mounted with pot accessory.

Ref. 4815.

Accessory.



#### Personalization options available

- LED 3500 K

Request more information.

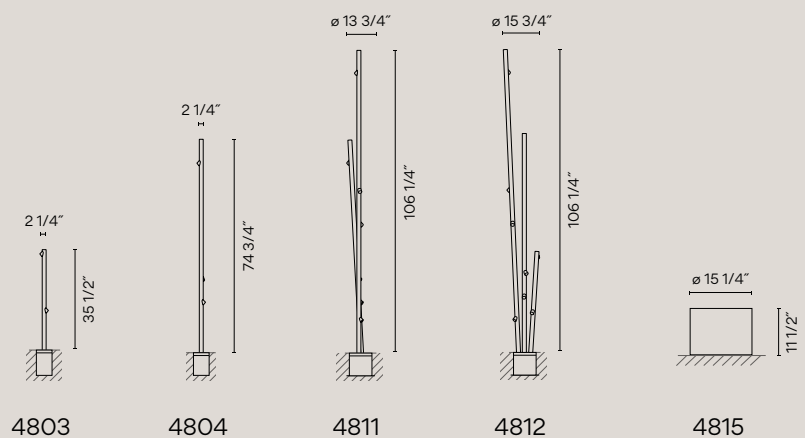

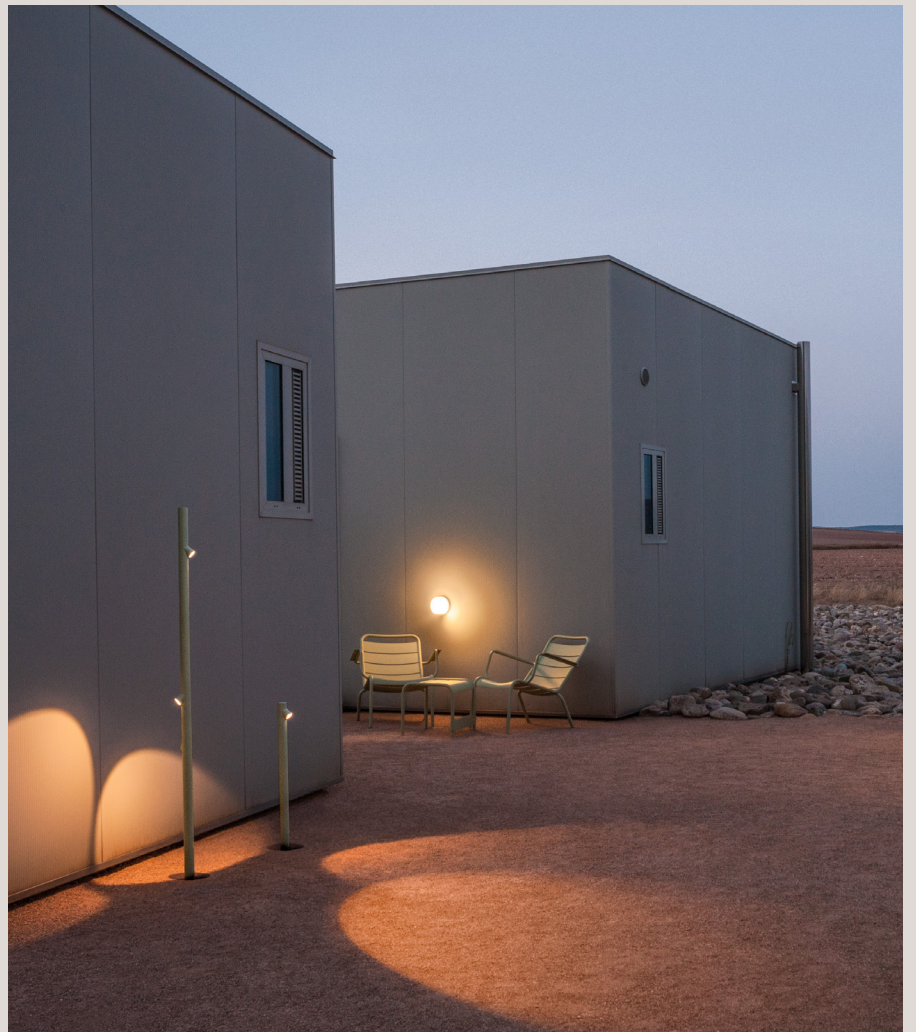

# Wind

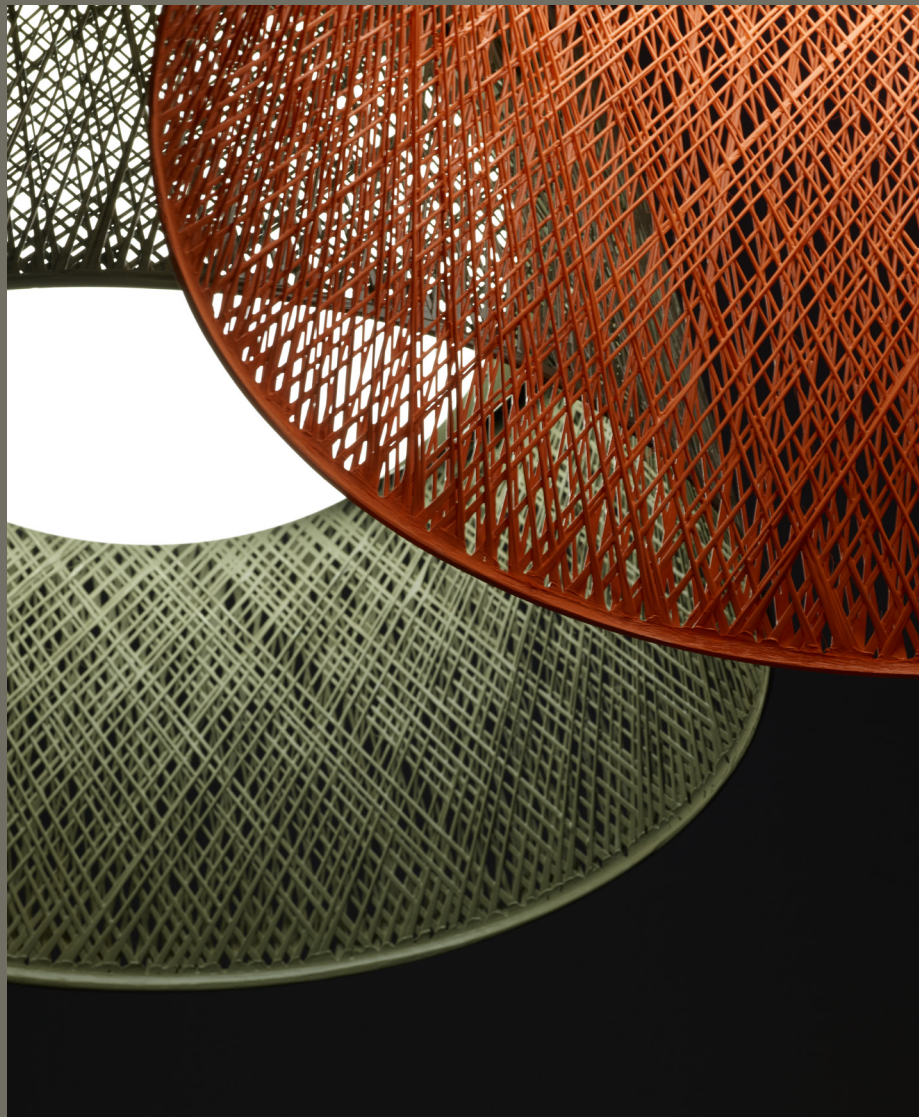

Design by Jordi Vilardell.

A perfect marriage of technology and tradition. Wind's drum shade is made of fibreglass, an innovative webbed texture and pattern that elevates the visual contribution of this timeless silhouette.



Distinguished by its large scale and striking silhouette, Wind makes a powerful statement in any outdoor setting. A perfect marriage of technology and tradition, the drum shade is intricately woven of fibreglass, creating a webbed texture and pattern that elevates its textural interest and makes it versatile enough for traditional or modern settings. Wind is available in pendant and floor versions and emits an ambient glow.

- 27 Brown L1 (S 1505-Y50R)
- 53 Green M1 (S 6005-G80Y)
- 61 Ocre Red (S 3050-Y60R)

Shade: Woven fibreglass.  
 Lid: Steel.  
 Diffuser: Methacrylate.  
 Canopy Ref. 4077: Steel.  
 Weight Ref. 4057: Concrete.

LED 2700K. CRI >90. 25W. 3480 lm.

Ref. 4057.  
 Driver included 120V.  
 Portable version.

Ref. 4077.  
 Driver included 120-277V.  
 Surface mounted.



**Personalization options available**  
 - LED 3500 K  
 Request more information,  
[sales@vibia.com](mailto:sales@vibia.com)

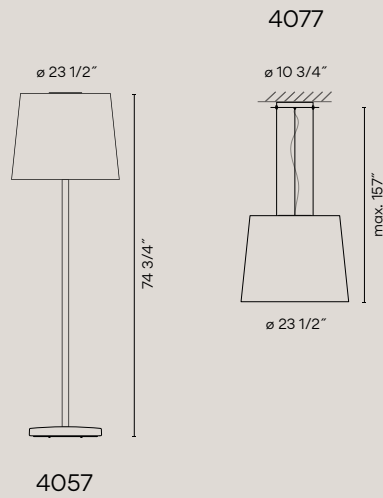





# Break

Design by Xuclà & Alemany.

Resembling an avant-garde sculpture, Break is distinguished by its architectural attitude. The cubic volumes angle provides down light, while doubling as sculptural outdoor presence.









Resembling an avant-garde sculpture, Break is distinguished by its architectural attitude. The fixture features cubic volumes angle provides down light, while doubling as sculptural presence to complement an outdoor setting. Break is available in two types of floor lamps—one a beveled cube that creates a powerful beam of light to illuminate the area around it; the other a vertical stack of two shapes through which light shines. It's also offered in a wall lamp, which reflects light outwards through a slot between it and the wall on which it's mounted.

Ref. 4101, 4106, 4110.

● 54 Oxide (Ral 8017)

● 80 Concrete (Natural finish)

Ref. 4108.

● 54 Oxide (Ral 8017)

Ref. 4101, 4106, 4110.

Body: Aluminum / concrete.

Diffuser: Methacrylate.

Ref. 4108.

Body: Steel.

Diffuser: Methacrylate.

Ref. 4101, 4106.

LED 2700 K. CRI >80. 6.2W. 616 lm.

Surface mounted.

Ref. 4108.

LED 2700 K. CRI >80. 18.4 W. 2840 lm.

Surface mounted.

Ref. 4110.

LED 2700 K. CRI >80. 2.1W. 199 lm.

Wall mounted.



#### Personalization options available

- LED 3500 K

Request more information  
sales@vibia.com.

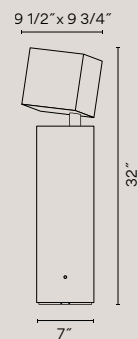

4101

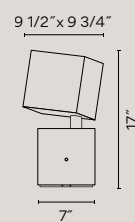

4106

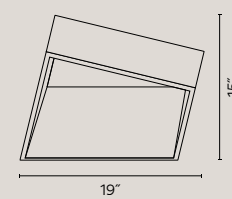

4108

4110

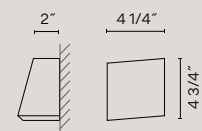



# Plus

Design by X. Claramunt & M. de Mas.

Adopting the form and function of a skylight, Plus' streamlined, spherical form integrates seamlessly into the ceiling architecture of outdoor spaces like porches or walkways. Its diffuser lends the dimmable light an ambient, uniform quality.

---

● 03 White (RAL 9010)

Body: Polyurethane.  
Diffuser: Methacrylate.  
Ceiling support: Steel.

---

LED 3500 K. CRI >90. 20W. 2420 lm.  
Dimming: 0-10V.

Surface mounted.



---

**Personalization options available**

- LED 3000 K  
- Dimming: DALI or LUTRON ECO  
Request more information,  
[sales@vibia.com](mailto:sales@vibia.com).

0632

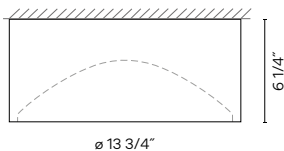







# Micro

Design by Ramos & Bassols.

Powered by an LED light source tucked between its two circular forms, Micro's diminutive design recalls a solar eclipse casting a glowing nimbus of light.

As its name suggests, Micro is distinguished by a diminutive, yet precise design that measures a mere 5 inches.

A pleasing interplay of concentric circles, its simple, spherical base attaches to the wall and is superimposed by a smaller, protruding ring. Powered by an LED tucked between the two layers, it recalls a solar eclipse casting a glowing nimbus of light.

● 03 White (Ral 9016)

Body: Aluminum.  
Diffuser: Polycarbonate.

LED 2700 K. CRI >80. 1W. 365 lm.

Surface mounted.



#### Personalization options available

- LED 3500 K  
Request more information,  
[sales@vibia.com](mailto:sales@vibia.com)



2015

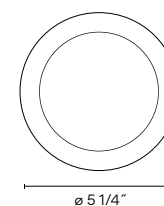
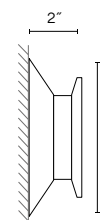

# Scotch

Design by Oscar & Sergi Devesa.

Evoking a sleek ice sculpture,  
Scotch is at once strong and subtle.



---

Crafted of a thick, pressed-glass diffuser resting upon a chrome base, its simple, spherical design provides an understated accent. It features a frosted-glass interior that generates a warm glow, ideal for outdoor ceiling soffits or walls.

● 01 Chrome

Body: Zamak.  
Diffuser: Glass.

---

LED 2700 K. CRI >80. 3W. 341 lm.

Surface mounted.

---



---

**Personalization options available**

- LED 3500 K  
Request more information,  
[sales@vibia.com](mailto:sales@vibia.com)

0962

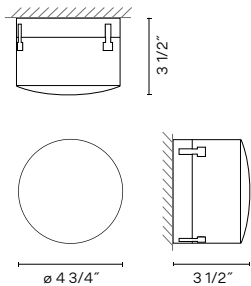

# Plis Outdoor

Design by Ramos & Bassols.

A surprising design which brings the warm atmosphere and textures of the indoors to the garden, terrace or porch. Breaking down boundaries between inside and outside.

---

Marked by its tailored pleated shade, Plis features the classic silhouette of an indoor lamp reimaged for the outdoors. Free of any embellishment apart from the crisp pleating, Plis provides a contemporary, yet timeless feel. Available in a floor version, it casts a warm, welcoming glow.

● 03 White (RAL 9016)

Base: Polyurethane.  
Cover: Steel.  
Diffuser: Polyethylene.

---

Compact fluorescent (not provided).  
Compatible with 120V.

---

Ref. 4030.  
Portable version with cable.

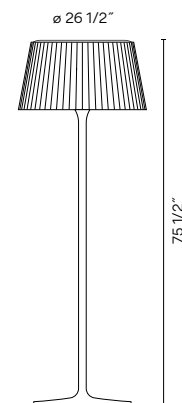

4030





# Empty

Design by Xuclà.

A sculpture by day and lighting by night, this outdoor fixture embodies multifunctional design. Its crisp angles create a cantilevered perch that serves as a side table or stool.





A sculpture by day and lighting by night, Empty is the embodiment of multifunctional design. Floor lamp and furnishing in one, Empty's crisp angles create a cantilevered perch that serves as a side table or stool, while making a sleek modernist statement. A LED light source tucked discreetly under the seat casts a warm glow that's ideal for walkways or general exterior illumination.

● 18 Concrete (S 2002-B50G)

Body: Polymer concrete.  
Diffuser: Methacrylate.

Ref. 4125, 4130.  
LED 3500 K. CRI >70. 2 x 8.6W. 1247 lm.  
Driver included 120-277V.

Ref. 4136, 4135.  
LED 3500 K. CRI >70. 2 x 4.3W. 567 lm.  
Driver included 120V.

Ground surface mounted.

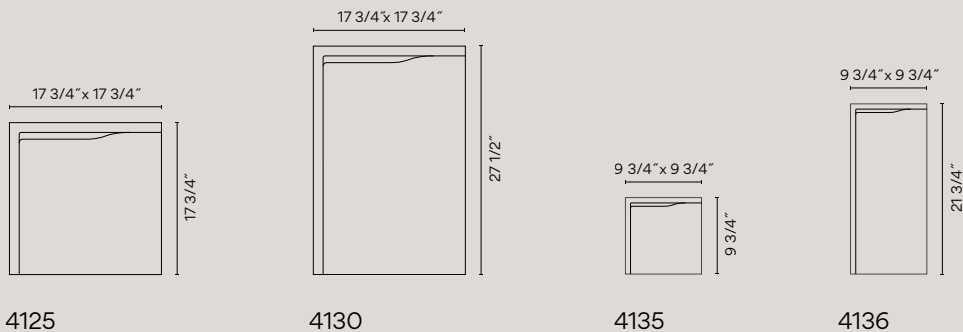
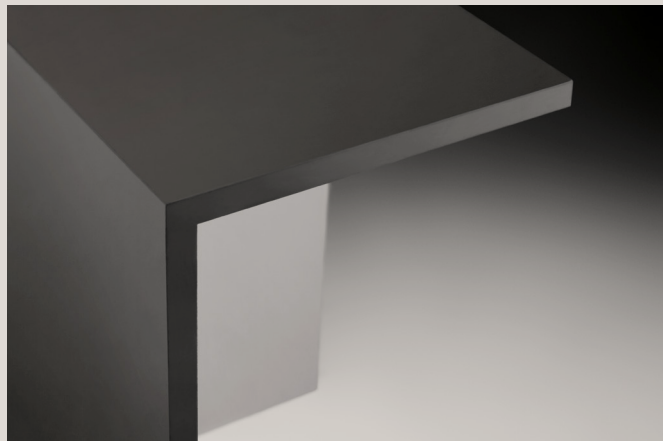
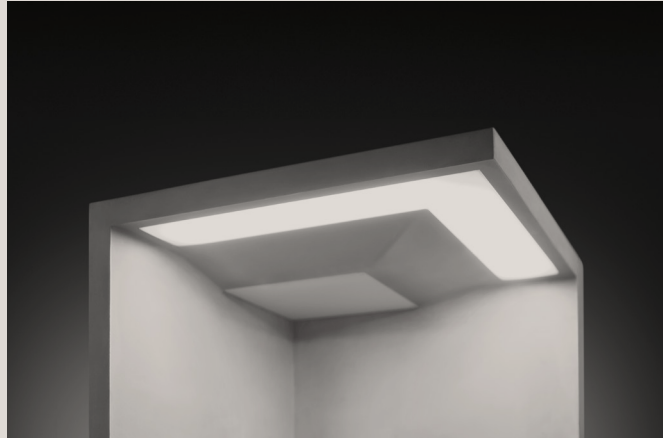







# Palo Alto

Design by Xuclà.

At once natural and architectural, Palo Alto creates the effect of illuminated landscaping. Its angular, tree-shaped silhouette integrates seamlessly with the outdoors whether displayed individually or in a group.













At once natural and architectural, Palo Alto creates the effect of illuminated landscaping. Sleek and streamlined, its angular, tree-shaped silhouette integrates seamlessly with the outdoors. It's offered in various minimalist shapes and can be displayed individually or in a group to resemble a stand of trees. The upper reaches of the sturdy steel fixture are fitted with slim swaths of LEDs directed downwards to create diffuse, ambient glow.

- 29 Brown D1 (NCS S 8005-Y50R)
- 53 Green M1 (NCS S 6005-G80Y)

Body: Steel.  
 Cover: Steel.  
 Diffuser: Polycarbonate.

LED 2700 K. CRI>80. 80 lm/W.

**Personalization options available**

- LED 3500 K.  
 Ref. 4516, 4521
  - Remote driver dimming:  
 1-10V, DALI, LUTRON ECO  
 Ref. 4537, 4538
  - Remote driver dimming: LUTRON  
 ECO
  - Dimming: 1-10V, DALI
- Request for more information.  
[sales@vibia.com](mailto:sales@vibia.com)

Ground surface mounted.



4516

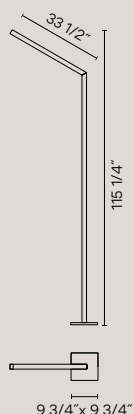

4521

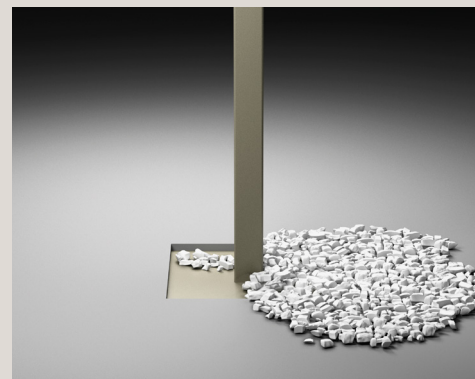
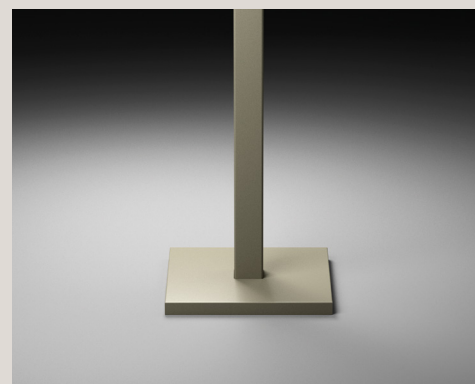
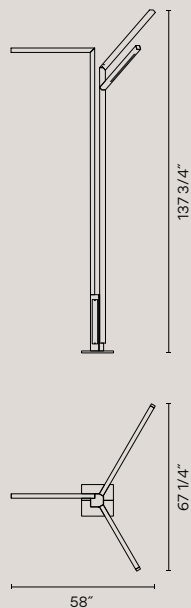
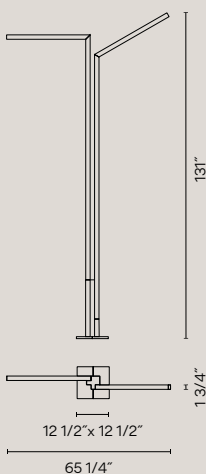



# Meridiano

Design by Jordi Vilardell & Meritxell Vidal.

Meridiano features a grid of steel slots through which LED light radiates outwards in a dramatic sunburst pattern. Topped with foam, it doubles as a seat or side table, its airy architecture integrating easily into outdoor spaces.











Meridiano is formed from a spherical steel shade fitted with open slots. An ambient LED shines through the diffuser, radiating outward from the grid across a broad surface in a dramatic sunburst pattern of shadow and light. The bench topped with foam, it doubles as a seat or side table, its airy architecture integrating easily into outdoor spaces.

- 07 Beige grey (RAL 7006)
- 58 Off-white (PANTONE WARM GRAY 2U)

Bench  
Rods: Steel.  
Arm: Steel.  
Seat: Polyurethane.  
Diffuser: Glass.

Wall  
Shade: Steel.  
Diffuser: Polycarbonate.  
Base: Aluminum.

LED 2700 K. CRI>80.

Ref. 4710, 4715.  
Ground surface mounted.

Ref. 4720.  
Wall surface mounted.

#### Personalization options available

- LED 3500 K
- Ref. 4710, 4715
- Dimming: 0-10V
- Remote driver dimming:  
0-10V, DALI, LUTRON ECO

Request for more  
information.  
[sales@vibia.com](mailto:sales@vibia.com)

4720

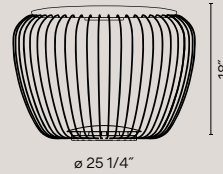
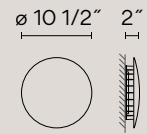

ø 25 1/4"

4710

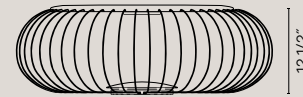

ø 36 1/4"

4715









The contents of this catalog may be changed or cancelled at the discretion of the VIBIA management without prior notice.

## VIBIA, INC.

USA & CANADA  
272 Fernwood Ave.  
Edison, NJ 08837. USA  
Phone 732 417 1700.  
Fax 732 417 1701.

[sales@vibia.com](mailto:sales@vibia.com)  
[www.vibia.com](http://www.vibia.com)

HEADQUARTERS  
Progrés 4-6.  
08850 Gavà  
(Barcelona - Spain)



